

7SR11 and 7SR12

Commissioning and Maintenance Guide

Document Release History

This document is issue 2012/02. The list of revisions up to and including this issue is:

2012/02	AC auxiliary power supply added
2012/01	Software Maintenance
2011/06	Software Maintenance
2010/04	Amendments following PLM review
2010/02	Document reformat due to rebrand
2009/09	Revised format
2009/04	First Issue

Software Revision History

2012/01	7SR11 2436H80003 R2a-2a 7SR12 2436H80004 R2a-2a	Software Maintenance
2011/06	7SR11 2436H80003 R2-2 7SR12 2436H80004 R2-2	Software Maintenance
2009/04	2436H80003R1g-1c 7SR11 2436H80004R1g-1c 7SR12	First Release

The copyright and other intellectual property rights in this document, and in any model or article produced from it (and including any registered or unregistered design rights) are the property of Siemens Protection Devices Limited. No part of this document shall be reproduced or modified or stored in another form, in any data retrieval system, without the permission of Siemens Protection Devices Limited, nor shall any model or article be reproduced from this document unless Siemens Protection Devices Limited consent.

While the information and guidance given in this document is believed to be correct, no liability shall be accepted for any loss or damage caused by any error or omission, whether such error or omission is the result of negligence or any other cause. Any and all such liability is disclaimed.

Contents

Section 1: Common Functions	5
1.1 Overview	5
1.2 Before Testing	5
1.2.1 Safety	5
1.2.2 Sequence of Tests	5
1.2.3 Test Equipment	6
1.2.4 Use of PC to facilitate testing	6
1.2.5 Precautions	6
1.2.6 Applying Settings	6
1.3 Tests	7
1.3.1 Inspection	7
1.3.2 Secondary Injection Tests	7
1.3.3 Primary Injection Tests	7
1.3.4 Putting into Service	7
1.4 AC Analogue Energising Quantities	8
1.5 Binary Inputs	8
1.6 Binary Outputs	9
1.7 Relay Case Shorting Contacts	9
Section 2: Protection Functions	10
2.1 Phase Directional Polarity Check	11
2.1.1 2 out of 3 logic	13
2.2 Phase Overcurrent (67/50,67/51)	13
2.2.1 Definite Time Overcurrent (50)	14
2.2.2 Inverse Time Overcurrent (51)	14
2.3 Voltage Controlled Overcurrent (51V)	16
2.4 Cold Load (51C)	18
2.4.1 Inverse Time Overcurrent (51C)	19
2.5 Directional Earth Fault Polarity Check (67N)	22
2.6 Derived Earth Fault (67/50N, 67/51N)	23
2.6.1 Directional Polarity	24
2.6.2 Definite Time Overcurrent (50N)	24
2.6.3 Inverse Time Overcurrent (51N)	24
2.7 Measured Earth fault (67/50G,67/51G)	27
2.7.1 Directional Polarity	28
2.7.2 Definite Time Overcurrent (67/50G)	28
2.7.3 Inverse Time Overcurrent (67/51G)	28
2.8 Sensitive Earth fault (67/50S,67/51S)	31
2.8.1 Directional Polarity	31
2.8.2 Definite Time Overcurrent (50SEF)	32
2.8.3 Wattmetric Protection	32
2.8.4 Inverse Time Overcurrent (51SEF)	33
2.9 Restricted Earth fault (64H)	35
2.10 Negative Phase Sequence Overcurrent (46NPS)	37
2.10.1 Definite Time NPS Overcurrent (46DT)	38
2.10.2 Inverse Time NPS Overcurrent (46IT)	38
2.11 Undercurrent (37)	40
2.12 Thermal Overload (49)	42
2.13 Over/Under Voltage	44
2.13.1 Phase Under/Over Voltage (27/59)	44
2.13.2 Undervoltage Guard (27/59UVG)	46
2.13.3 NPS Overvoltage (47)	46
2.13.4 Neutral Overvoltage (59N)	48
2.13.5 Definite Time (59NDT)	48
2.13.6 Inverse Time (59NIT)	49
2.14 Under/Over Frequency (81)	50

Section 3: Supervision Functions	52
3.1 CB Fail (50BF)	52
3.1.1 Element Blocking	53
3.2 Voltage Transformer Supervision (60VTS)	54
3.2.1 1 or 2 Phase VT fail	54
3.2.2 3 Phase VT fail.....	55
3.3 Current Transformer Supervision (60CTS)	56
3.3.1 7SR11	56
3.3.2 7SR12.....	57
3.4 Broken Conductor (46BC).....	58
3.5 Trip/Close Circuit Supervision (74T/CCS).....	60
3.6 Magnetising Inrush Detector (81HBL).....	61
Section 4: Control & Logic Functions	62
4.1 Autoreclose (79).....	62
4.2 Quick Logic	62
Section 5: Testing and Maintenance	63
5.1 Periodic Tests	63
5.2 Maintenance	63
5.3 Troubleshooting	63

List of Figures

Figure 2-1	Directional Phase Fault Boundary System Angles	12
Figure 2-2	Phase Overcurrent.....	13
Figure 2-3	Voltage Controlled Overcurrent	16
Figure 2-4	Cold Load.....	18
Figure 2-5	Cold Load Logic diagram.....	19
Figure 2-6	Directional Earth Fault Boundary System Angles.....	22
Figure 2-7	Derived Earth Fault	23
Figure 2-8	Measured Earth Fault	27
Figure 2-9	Sensitive Earth Fault.....	31
Figure 2-10	Restricted Earth Fault	35
Figure 2-11	Negative Phase Sequence Overcurrent	37
Figure 2-12	Undercurrent	40
Figure 2-13	Thermal Overload	42
Figure 2-14	Phase Under/Over Voltage.....	44
Figure 2-15	NPS Overvoltage	46
Figure 2-16	Neutral Overvoltage	48
Figure 2-17	Under/Over Frequency	50
Figure 3-1	CB Fail	52
Figure 3-2	Voltage Transformer Supervision	54
Figure 3-3	Current Transformer Supervision 7SR11	56
Figure 3-4	Current Transformer Supervision 7SR12	57
Figure 3-5	Broken Conductor.....	58
Figure 3-6	Trip Circuit Supervision.....	60
Figure 3-7	Magnetising Inrush Detector.....	61

List of Tables

Table 5-1	Troubleshooting Guide	64
-----------	-----------------------------	----

Section 1: Common Functions

1.1 Overview

Commissioning tests are carried out to prove:

- a) Equipment has not been damaged in transit.
- b) Equipment has been correctly connected and installed.
- c) Characteristics of the protection and settings which are based on calculations.
- d) Confirm that settings have been correctly applied.
- e) To obtain a set of test results for future reference.

1.2 Before Testing

1.2.1 Safety

The commissioning and maintenance of this equipment should only be carried out by skilled personnel trained in protective relay maintenance and capable of observing all the safety precautions and regulations appropriate to this type of equipment and also the associated primary plant.

Ensure that all test equipment and leads have been correctly maintained and are in good condition. It is recommended that all power supplies to test equipment be connected via a Residual Current Device (RCD), which should be located as close to the supply source as possible.

The choice of test instrument and test leads must be appropriate to the application. Fused instrument leads should be used when measurements of power sources are involved, since the selection of an inappropriate range on a multi-range instrument could lead to a dangerous flashover. Fused test leads should not be used where the measurement of a current transformer (C.T.) secondary current is involved, the failure or blowing of an instrument fuse or the operation of an instrument cut-out could cause the secondary winding of the C.T. to become an open circuit.

Open circuit secondary windings on energised current transformers are a hazard that can produce high voltages dangerous to personnel and damaging to equipment, test procedures must be devised so as to eliminate this risk.

1.2.2 Sequence of Tests

If other equipment is to be tested at the same time, then such testing must be co-ordinated to avoid danger to personnel and equipment.

When cabling and wiring is complete, a comprehensive check of all terminations for tightness and compliance with the approved diagrams must be carried out. This can then be followed by the insulation resistance tests, which if satisfactory allows the wiring to be energised by either the appropriate supply or test supplies.

When primary injection tests are completed satisfactorily, all remaining systems can be functionally tested before the primary circuit is energised. Some circuits may require further tests before being put on load.

Protection relay testing will require access to the protection system wiring diagrams, relay configuration information and protection settings. The following sequence of tests is loosely based on the arrangement of the relay menu structure. A test log based on the actual tests completed should be recorded for each relay tested.

The 'Description of Operation' section of this manual provides detailed information regarding the operation of each function of the relay. All functions are not available in all devices, please refer the 'Description of Operation' section to establish your function set.

1.2.3 Test Equipment

Required test equipment is:

1. Secondary injection equipment with integral time interval meter
2. Primary injection equipment
3. A power source with nominal voltage within the working range of the relay's auxiliary supply rating.
4. A power source with nominal voltage within the working range of the relay's binary input rating.
5. Other equipment as appropriate to the protection being commissioned – this will be specified in the product specific documentation.

The secondary injection equipment should be appropriate to the protection functions to be tested. Additional equipment for general tests and for testing the communications channel is:

6. Portable PC with appropriate interface equipment.
7. Printer to operate from the above PC (Optional).

1.2.4 Use of PC to facilitate testing

The functions of Reydisp Evolution (see Section 2: Settings and Instruments) can be used during the commissioning tests to assist with test procedures or to provide documentation recording the test and test parameters. One method is to clear both the waveform and event records before each test is started, then, after the test upload from the relay the settings, events and waveform files generated as a result of application of the test. These can then be saved off to retain a comprehensive record of that test.

Relay settings files can be prepared on the PC (offline) or on the relay before testing commences. These settings should be saved for reference and compared with the settings at the end of testing to check that errors have not been introduced during testing and that any temporary changes to settings to suit the test process are returned to the required service state.

A copy of the Relay Settings as a Rich Text Format (.rtf) file suitable for printing or for record purposes can be produced from Reydisp as follows. From the *File* menu select *Save As*, change the file type to *Export Default/Actual Setting (.RTF)* and input a suitable filename.

When testing is completed the event and waveform records should be cleared and the settings file checked to ensure that the required in-service settings are being applied.

1.2.5 Precautions

Before electrical testing commences the equipment should be isolated from the current and voltage transformers. The current transformers should be short-circuited in line with the local site procedure. The tripping and alarm circuits should also be isolated where practical. The provision and use of secondary injection test sockets on the panel simplifies the isolation and test procedure.

Ensure that the correct auxiliary supply voltage and polarity is applied. See the relevant scheme diagrams for the relay connections.

Check that the nominal secondary current rating of the current and voltage transformers has been correctly set in the System Config. menu of the relay.

1.2.6 Applying Settings

The relay settings for the particular application should be applied before any secondary testing occurs. If they are not available then the relay has default settings that can be used for pre-commissioning tests. See the Relay Settings section of this manual for the default settings.

Note that the tripping and alarm contacts for any function must be programmed correctly before any scheme tests are carried out.

Relays feature multiple settings groups, only one of which is active at a time. In applications where more than one settings group is to be used it may be necessary to test the relay in more than one configuration.

Note. One group may be used as a 'Test' group to hold test-only settings that can be used for regular maintenance testing, eliminating the need for the Test Engineer to interfere with the actual in-service settings in the normally active group. This Test group may also be used for functional testing where it is necessary to disable or change settings to facilitate testing.

When using settings groups it is important to remember that the relay need not necessarily be operating according to the settings that are currently being displayed. There is an 'active settings group' on which the relay

operates and an 'edit/view settings group' which is visible on the display and which can be altered. This allows the settings in one group to be altered from the relay fascia while the protection continues to operate on a different unaffected group. The 'Active Settings Group' and the 'Edit Settings Group' are selected in the 'System Configuration Menu'.

The currently Active Group and the group currently Viewed are shown at the top of the display in the Settings display screen. If the View Group is not shown at the top of the display, this indicates that the setting is common to all groups. CT/VT ratio, I/O mapping and other settings which are directly related to hardware are common to all groups.

If the relay is allowed to trip during testing then the instruments display will be interrupted and replaced by the 'Trip Alert' screen which displays fault data information. If this normal operation interferes with testing then this function can be temporarily disabled for the duration of testing by use of the Trip Alert Enabled/Disabled setting in the System Config Menu.

After applying a settings change to the relay, which may involve a change to the indication and output contacts, the **TEST/RESET** key should be pressed to ensure any existing indication and output is correctly cleared.

1.3 Tests

1.3.1 Inspection

Ensure that all connections are tight and correct to the relay wiring diagram and the scheme diagram. Record any deviations. Check that the relay is correctly programmed and that it is fully inserted into the case. Refer to 'Section 2: Settings and Instruments' for information on programming the relay.

1.3.2 Secondary Injection Tests

Select the required relay configuration and settings for the application.

Isolate the auxiliary D.C. supplies for alarm and tripping from the relay and remove the trip and intertrip links.

Carry out injection tests for each relay function, as described in this document

For all high current tests it must be ensured that the test equipment has the required rating and stability and that the relay is not stressed beyond its thermal limit.

1.3.3 Primary Injection Tests

Primary injection tests are essential to check the ratio and polarity of the transformers as well as the secondary wiring.

Note. If the current transformers associated with the protection are located in power transformer bushings it may not be possible to apply test connections between the current transformer and the power transformer windings. Primary injection is needed, however, to verify the polarity of the CTs. In these circumstances primary current must be injected through the associated power transformer winding. It may be necessary to short circuit another winding in order to allow current to flow. During these primary injection tests the injected current is likely to be small due to the impedance of the transformer.

1.3.4 Putting into Service

After tests have been performed satisfactorily the relay should be put back into service as follows:-

Remove all test connections.

Replace all secondary circuit fuses and links, or close m.c.b.

Ensure the Protection Healthy LED is on, steady, and that all LED indications are correct. If necessary press **CANCEL** until the Relay Identifier screen is displayed, then press **TEST/RESET** to reset the indication LEDs.

The relay meters should be checked in Instruments Mode with the relay on load.

The relay settings should be downloaded to a computer and a printout of the settings produced. The installed settings should then be compared against the required settings supplied before testing began. Automated setting comparison can be carried out by Reydisp using the *Compare Settings Groups* function in the *Edit* menu. Any modified settings will be clearly highlighted.

1.4 AC Analogue Energising Quantities

Voltage and current measurement for each input channel is displayed in the Instrumentation Mode sub-menus, each input should be checked for correct connection and measurement accuracy by single phase secondary injection at nominal levels. Ensure that the correct instrument displays the applied signal within limits of the Performance Specification.

	Applied Current.....					Applied Voltage.....			
	I _A	I _B	I _C	I _{G/SEF}	Tol	V _A /V _{AB}	V _B /V _{BC}	V _C /V _{CB}	Tolerance
Secondary									
Primary									

Apply 3 phase balanced Current and Voltage at nominal levels and ensure that the measured Zero Phase Sequence and Negative Phase Sequence quantities are approximately zero.

	ZPS	NPS
Voltage		
Current		

1.5 Binary Inputs

The operation of the binary input(s) can be monitored on the 'Binary Input Meters' display shown in 'Instruments Mode'. Apply the required supply voltage onto each binary input in turn and check for correct operation. Depending on the application, each binary input may be programmed to perform a specific function; each binary should be checked to prove that its mapping and functionality is as set as part of the Scheme Operation tests.

Where the pick-up timers associated with a binary input are set for DC operation these delays should be checked either as part of the scheme logic or individually. To check a binary pick-up time delay, temporarily map the binary input to an output relay that has a normally open contact. This can be achieved in the Output Matrix sub-menu by utilising the *BI n Operated* settings. Use an external timer to measure the interval between binary input energisation and closure of the output contacts. Similarly, to measure the drop-off delay, map the binary input to an output relay that has a normally closed contact, time the interval between binary input de-energisation and closure of the output contacts.

For AC operation of binary inputs, these timers are used to ensure correct operation from AC voltage and if a delayed pickup is required this must be provided by additional quicklogic configuration. An example is shown in Chapter 7 – Applications Guide.

Note. The time measured will include an additional delay, typically less than 20ms, due to the response time of the binary input hardware, software processing time and the operate time of the output relay.

BI	Tested	DO Delay	Measured	PU Delay	Measured	Notes (method of initiation)
1						
2						
3						
4						
5						
6						

1.6 Binary Outputs

A minimum of five output relays are provided. Two of these have change over contacts, BO1 & BO2 and the remainder have normally open contacts.

Care should be observed with regard to connected devices when forcing contacts to operate for test purposes. Short duration energisation can cause contact failure due to exceeding the break capacity when connected to inductive load such as electrically reset trip relays.

Close each output relay in turn from the Reydisp Evolution PC programme, Relay – Control - Close output relay. This function will energise the output for its minimum operate time. This time is specified in the Output Config - Binary Output Config menu for each output relay and may be too short to measure with a continuity tester.

An alternative method of energising an output permanently so that wiring can be checked is to temporarily map the relay being tested to the 'Protection Healthy' signal in the Output Matrix, as this signal is permanently energised the mapped relay will be held energised, normally open contacts will be closed and vice versa.

BO	Checked	Notes (method of test)
1NO		
1NC		
2NO		
2NC		
3		
4		
5		
6		
7		
8		

1.7 Relay Case Shorting Contacts

CT input terminals and the terminals of normally closed contacts of Binary outputs 1 & 2 are fitted with case mounted shorting contacts which provide a closed contact when the relay is withdrawn from the case. The operation of these contacts should be checked.

CT Shorting contacts checked	
Binary Output 1 terminals 1 & 2 Alarm Checked	
Binary Output 2 terminals 5 & 6 Alarm Checked	

Section 2: Protection Functions

This section details the procedures for testing each protection function of the 7SR11 & 7SR12 relays. These tests are carried out to verify the accuracy of the protection pick-ups and time delays at setting and to confirm correct operation of any associated input and output functionality.

The exact model type must be checked to confirm the functions available in each type.

Guidance for calculating test input quantities is given in the relevant test description where required. In many cases it may be necessary to disable some functions during the testing of other functions, this prevents any ambiguity caused by the operation of multiple functions from one set of input quantities. The 'Function Config' Menu provides a convenient high level point at which all elements of a particular function can be Enabled/Disabled to suit testing. The 'Config' tab in 'Reydisp Evolution' can be used to 'Enable/Disable' individual elements. Note that this screen disables functions by applying setting changes to the relay and that any changes must be sent to the relay to take effect and settings must be returned to their correct value after testing.

The table below indicates functions where function conflicts may occur during testing, consideration should be given to disabling functions to avoid interference.

Function Under Test	Phase Overcurrent	Voltage Cont O/C	Cold Load	Derived E/F	Measured E/F	Sensitive E/F	Restricted E/F	NPS Overcurrent	Undercurrent	Thermal	Phase U/O voltage	NPS Overvoltage	CB Fail	VT Supervision	CT supervision	Broken Conductor	Trip cct Supervision	Inrush Detector
Phase		○	○					○	○	○			○			○		
Voltage Cont O/C	○		○					○	○	○			○			○		
Cold Load	○	○						○	○	○			○			○		
Derived E/F					○			○	○	○			○		○	○		
Measured E/F				○				○	○	○								
Sensitive E/F							○											
Restricted E/F						○												
NPS Overcurrent	○	○	○						○	○			○		○			
Undercurrent				○	○			○										
Thermal	○	○	○										○					
Phase U/O voltage												○	○	○				
NPS Overvoltage											○		○	○				
CB Fail	○	○	○	○	○	○		○		○								
VT Supervision											○	○						
CT supervision				○												○		
Broken Conductor				○				○	○						○			
Trip cct																		
Inrush Detector																		

Any LED can be assigned to be a General Pickup LED in the Output Matrix menu and used to assess operation of functions during testing if other functions are disabled or if the setting allocating General Pickup is temporarily modified.

Voltage inputs may not be required for testing of non-directional Overcurrent elements but it may be advantageous to apply balanced 3 phase nominal rated voltage to the VT inputs during testing to avoid inadvertent operation of other functions. Particular care should be taken when testing overcurrent functions that the thermal rating of the current inputs is not exceeded.

It should be considered that where several overlapping elements are used simultaneously, the overall protection operate time may be dependent on the operation of different individual elements at the various levels of applied current or voltage. The resulting composite characteristic may be tested by enabling all of the relevant applicable elements or the element operations can be separated or disabled and tested individually.

All relay settings should be checked before testing begins. It is recommended that the relay settings are extracted from the relay using Reydisp Evolution software and a copy of these settings is stored for reference during and after testing. It may be necessary to disable some protection functions during the testing of other functions to allow unambiguous results to be obtained.

Care must be taken to reset or re-enable any settings that have been temporarily altered during the testing before the relay can be put into service. At the end of testing the relay settings should be compared to the file extracted at the start to ensure that errors have not been introduced.

2.1 Phase Directional Polarity Check

If the relay has Directional Overcurrent elements, the common direction polarising can be checked independently from the individual overcurrent elements and their settings.

In the INSTRUMENTS MODE display, indication is provided in the DIRECTIONAL METERS menu which displays current direction under *P/F Dir* as forward or reverse based on the output states of the directional elements, i.e. whether they see forward current, reverse current or neither for each pole with respect to the *67 Char Angle* setting in the *Phase Overcurrent* menu. This display and the equivalent Measured and Calculated Earth Fault direction meters can be used as an aid to commissioning testing.

1. Check the direction of each pole in turn by connecting to the appropriate terminals. The table below shows the polarising quantity for each pole.

Connections for Directional Polarity

Overcurrent pole	Polarising voltage
Phase A	V_{BC}
Phase B	V_{CA}
Phase C	V_{AB}

2. Inject single phase rated current and apply single phase-phase rated voltage at the Char Angle (MTA) phase angle setting, to each phase in turn. For each pole, monitor the directional display in the instrument menu and check that indication of forward current (FWD) is displayed. To achieve the required forward Characteristic Angle, the phase angle of the current should be greater than that of the polarising voltage by the angle setting.
3. Repeat all of the above with the current connections reversed. Indication should now be given of reverse (REV) current flow.

Phase	A	B	C
Forward	FWD	FWD	FWD
Reverse	REV	REV	REV

4. Apply balanced 3 phase rated voltage and current with V_{bc} voltage as a 0deg reference and I_a at the characteristic angle. Increase current phase angle until the 'Fwd' indication is extinguished. Record this angle in the table below (Forward lead DO). Continue to increase/decrease the angle until the instrument reads 'Rev'. Record the angle (Reverse lead PU). Reduce the current angle until the 'Rev' extinguishes (Reverse lead DO), and the 'Fwd' subsequently returns (Forward lead PU), recording the angles. Repeat the above tests, starting from the Characteristic Angle, but reducing the current phase angle to record the directional boundaries in the opposite (lag) direction. The recorded angle should be the angle at which the phase current leads the phase-phase polarising voltage. This measurement is greatly simplified if the polarising reference voltage is set to 0deg and the current phase angle is measured with respect to this reference.

Alternatively, the instrument can be checked at the 4 points marked a,b,c & d on Figure 2-1 only.

	Forward				Reverse			
	Lag (point C)		Lead (point A)		Lead(point B)		Lag (point D)	
	Pick-up	Drop-off	Pick-up	Drop-off	Pick-up	Drop-off	Pick-up	Drop-off
MTA	MTA-85		MTA+85		MTA-85		MTA-85	
Phase A								
Phase B								
Phase C								

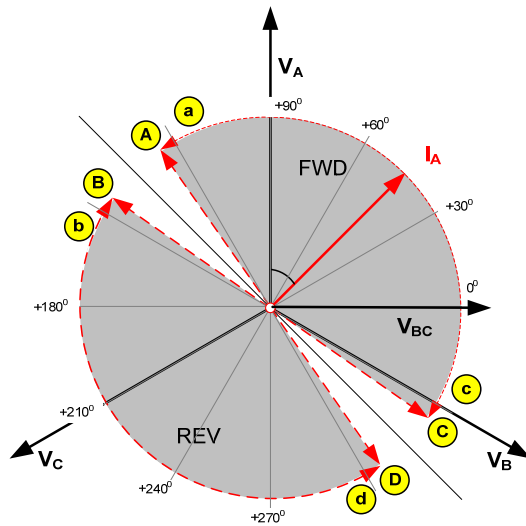

With balanced 3-phase system quantities:

Adjust the phase angle of the currents relative to the voltages:

Verify directional pick-up and drop off at points A, B, C and D

Alternatively,

Verify correct directional indication at points a, b, c and d (C.A +75°, +95°, -75°, -95°)

Figure 2-1 Directional Phase Fault Boundary System Angles

5. With the instrument reading 'Fwd' or 'Rev', reduce the voltage until the element resets. Record the minimum phase-phase operate voltage.

Minimum Voltage Setting	Measured

2.1.1 2 out of 3 logic

Ensure that at least 1 Phase Overcurrent element is set to Directional. Apply balanced nominal voltage. Apply current at a level above the 50/51 setting on phase A only at the characteristic angle for forward operation, normally 45° lagging. Ensure no Directional Phase Overcurrent element operation occurs. Note that non-directional Phase Overcurrent and Non-direction Earth Fault elements may operate unless disabled. Repeat the test with Phase A current as above but also with equal current in the B phase at 180° to that in the A phase.

1 phase current	2 phase current
No 50/51-n Operation	50/51-n operation

2.2 Phase Overcurrent (67/50,67/51)

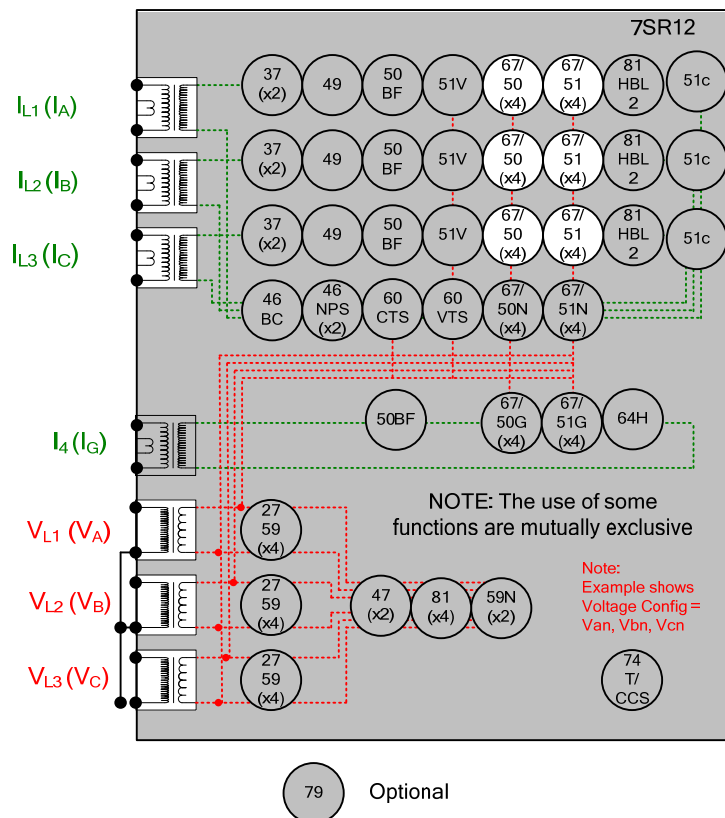

Figure 2-2 Phase Overcurrent

Voltage Inputs:	V_{L1} (V_A), V_{L2} (V_B), V_{L3} (V_C) for directional elements.
Current Inputs:	I_{L1} (I_A), I_{L2} (I_B), I_{L3} (I_C),
Disable:	51V, 51C, 46, 49, 50CBF, 79
Map Pickup LED:	51-n/50-n - Self Reset

Other protection functions may overlap with these functions during testing, it may be useful to disable some functions to avoid ambiguity. It should be particularly noted that if the function is enabled, the 51C Cold Load settings may modify the normal 50-n and 51-n settings if the CB is open during testing.

Voltage inputs may not be required for this function if the Phase Overcurrent functions are not directional but it may be advantageous to apply balanced 3 phase nominal rated voltage to the VT inputs during testing to avoid inadvertent operation of other functions. Particular care should be taken when testing overcurrent functions that the thermal rating of the current inputs is not exceeded.

2.2.1 Definite Time Overcurrent (50)

If DTL setting is small, gradually increase current until element operates.

If DTL is large apply 0.9x setting, check for no operation, apply 1.1x setting, check operation

Apply 2x setting current if possible and record operating time

Phase	Dir.	Is (Amps)	DTL (sec)	P.U. Current Amps	Tol	Operate Time 2 x Is	Tol
I _{L1} (IA)							
I _{L2} (IB)							
I _{L3} (IC)							

Check correct indication, trip output, alarm contacts, waveform record.

2.2.2 Inverse Time Overcurrent (51)

It will be advantageous to map the function being tested to temporarily drive the relevant Pickup output in the *Pickup Config* sub-menu in the *Output Config* menu as this will allow the Pick-up led to operate for the function.

Gradually increase current until Pickup LED operates.

Apply 2x setting current and record operating time,

Apply 5x setting current and record operating time.

Compare to calculated values for operating times.

Gradually reduce current until the element drops off and record the level.

P.U. D.O. & TIMING TESTS	Ph.	Dir	Char. Curve	Is (A)	TM	Operate Current			Operate Time		
						P.U. (Amps)	D.O. (Amps)	Tol	2 x Is (sec)	5 x Is (sec)	Tol
	I _{L1} (IA)										
	I _{L2} (IB)										
	I _{L3} (IC)										

Calculated Timing values in seconds for TM =1.0

Curve	2 x Is	5 x Is
IEC-NI	10.03	4.28
IEC-VI	13.50	3.38
IEC-EI	26.67	3.33
IEC-LTI	120.00	30.00
ANSI-MI	3.80	1.69
ANSI-VI	7.03	1.31
ANSI-EI	9.52	1.30

Note that the operate time may be subject to the **Minimum op time** setting for the element and/or may have a **Follower DTL** applied.

2.2.2.1 Element Blocking

The Phase Overcurrent elements can be blocked by Binary Input Inhibit, VT Supervision and Inrush Detector operation, as well as 79 Autoreclose settings for Inst/Delayed. The Characteristic can be modified by Cold Load (51-n only) and Voltage Controlled Overcurrent and can be made non-directional by VT Supervision. This functionality should be checked.

Element	BI Inhibits	VTS action	Inrush Detector	79 Autoreclose
51-1				
51-2				
51-3				
51-4				
50-1				
50-2				
50-3				
50-4				

2.2.2.2 ANSI Reset

If the element is configured as an ANSI characteristic, it may have an ANSI (decaying) reset delay applied. If ANSI reset is selected for an IEC characteristic element, the reset will be instantaneous.

ANSI reset times from operated condition to fully reset are as follows for zero applied current and Time multiplier (TM) = 1.0. The reset curve characteristic type and TM is defined by the operating characteristic.

Curve	Fully operated to reset with Zero current applied & TM=1 (secs)
ANSI-MI	4.85
ANSI-VI	21.6
ANSI-EI	29.1

Apply current in the following sequence, a) 2x setting for a time to ensure element operation, b) Zero current for the reset time above (xTM), c) 2x setting for a time to ensure element operation. Check that the second operation (c) is similar to the first (a) and in line with the expected operate time for the element at this current level.

Repeat the test with the reset time (b) reduced to 50% of the previous value. Ensure that the second operate time (c) is 50% of the first (a) operate time.

Operate time (expected)	Reset time (calculated)	Operate time (measured)	50% Reset Time (calculated)	50% operate time (calculated)	50% operate time (measured)
		First test (c)			Second Test (c)

Check correct indication, trip output, alarm contacts, waveform record.

2.2.2.3 IEC RESET

If the element is configured as an IEC characteristic, it may have an IEC (decaying) reset delay applied. If IEC reset is selected for an IEC characteristic element, the reset will be instantaneous.

IEC reset times from operated condition to fully reset are as follows for zero applied current and Time multiplier (TM) = 1.0. The reset curve characteristic type and TM is defined by the operating characteristic.

Curve	Fully operated to reset with Zero current applied & TM=1 (secs)
IEC-NI	9.7
IEC-VI	43.2
IEC-EI	58.2
IEC-LTI	80

Apply current in the following sequence, a) 2x setting for a time to ensure element operation, b) Zero current for the reset time above (xTM), c) 2x setting for a time to ensure element operation. Check that the second operation (c) is similar to the first (a) and in line with the expected operate time for the element at this current level.

Repeat the test with the reset time (b) reduced to 50% of the previous value. Ensure that the second operate time (c) is 50% of the first (a) operate time.

Check correct indication, trip output, alarm contacts, waveform record.

Operate time (expected)	Reset time (calculated)	Operate time (measured)	50% Reset Time (calculated)	50% operate time (calculated)	50% operate time (measured)
		First test (c)			Second Test (c)

2.3 Voltage Controlled Overcurrent (51V)

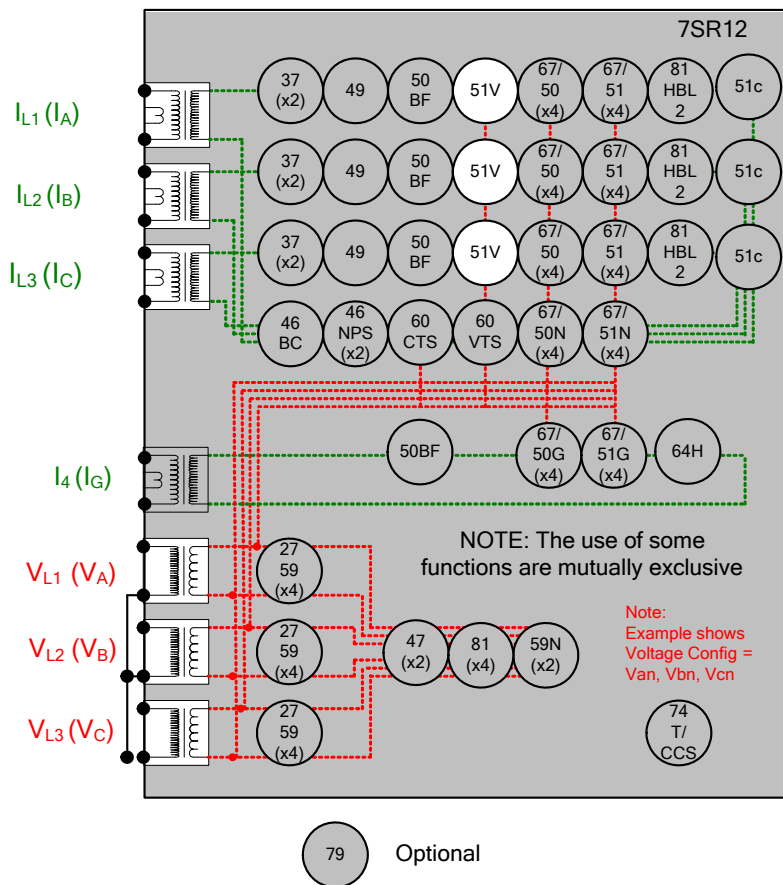

Figure 2-3 Voltage Controlled Overcurrent

OC Phase	Control Voltage
I _{L1} (I _A)	V ₁₂ (V _{AB})
I _{L2} (I _B)	V ₂₃ (V _{BC})
I _{L3} (I _C)	V ₃₁ (V _{CA})

- Voltage Inputs: V_{L1} (V_A), V_{L2} (V_B), V_{L3} (V_C)
- Current Inputs: I_{L1} (I_A), I_{L2} (I_B), I_{L3} (I_C),
- Disable: 51C, 46, 37, 49, 50CBF, 79
- Map Pickup LED: 51-n/50-n - Self Reset

Shaped Phase Overcurrent elements 51-n should be tested for pick-up and timing before this function is tested. The General Pickup LED can be used to assess operation of this function if other functions are disabled or if the setting allocating General Pickup is temporarily modified.

Apply nominal 3 phase balanced voltage. Apply 3 phase balanced current at a level below the normal 51-n setting but above the effective 51V-n setting. Ensure that the thermal rating of the relay is not exceeded. Gradually reduce the voltage until the a-b voltage is less than the Voltage setting. Pickup LED operation can be used to confirm the Voltage setting. If the 51V-n current setting is above the continuous rating of the relay an alternative procedure should be used, apply test current in short duration shots with applied voltage being gradually reduced for each subsequent shot

Apply nominal 3 phase balanced voltage. Increase the voltage such that the a-b voltage is 110% of the Voltage setting

Gradually increase the a-b phase current or balanced 3P current until Pickup LED operates. Confirm result of Phase O/C test above.

Reduce the applied voltage to a level such that $V_{12}(V_{AB})$ phase-phase voltage is less than 90% of the setting.

Gradually increase the $I_{12}(I_{AB})$ phase-phase current until Pickup LED operates.

Note that these elements may be set as directional. If this is the case, the phase angle of the current must be set with respect to the voltage to produce operation of the elements.

Voltage Setting (V, p-p)	Measured (V, p-p)

	I Setting	Multiplier	Calculated PU	Measured	Tolerance
51-1 Pickup					
51-2 Pickup					
51-3 Pickup					
51-4 Pickup					

2.3.1.1 Element Blocking

The Voltage Controlled Overcurrent function can be set to Inhibit for VT Supervision operation. This functionality should be checked. Apply balanced voltage and current. Reduce a-phase voltage to cause a VTS condition. Increase 3P current until the element operates at its full setting, i.e. 51V settings are not used.

Element	VTS action
51-1	
51-2	
51-3	
51-4	

Check correct indication, trip output, alarm contacts.

2.4 Cold Load (51C)

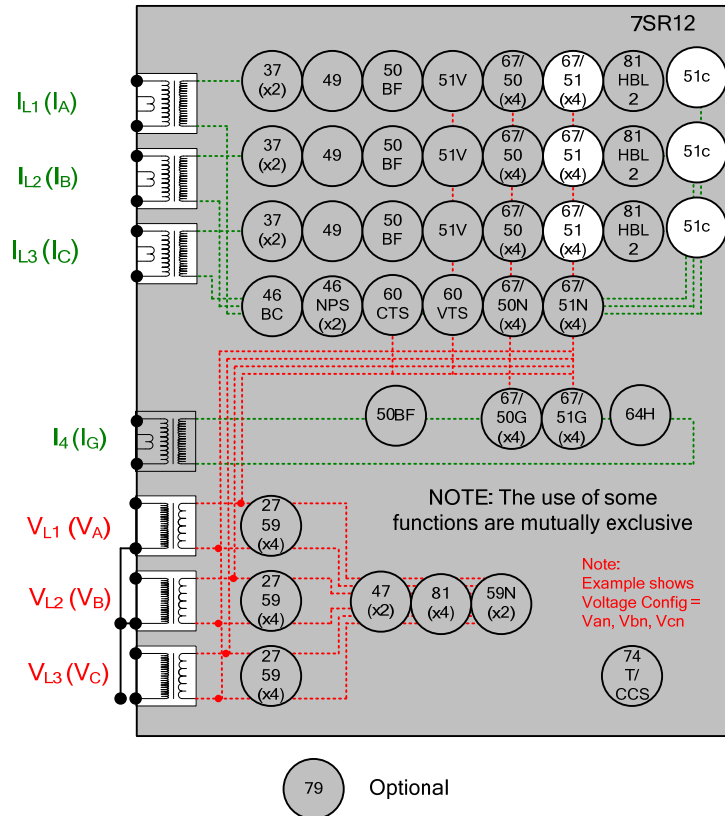

Figure 2-4 Cold Load

Voltage Inputs:	V_{L1} (V_A), V_{L2} (V_B), V_{L3} (V_C) for directional elements
Current Inputs:	I_{L1} (I_A), I_{L2} (I_B), I_{L3} (I_C),
Disable:	51V, 46, 49, 50CBF, 79
Map Pickup LED:	51-n - Self Reset

The CB must be open for more than the Cold Load *Pick-up Time* to allow testing of this function. It may be convenient to reduce this setting to suit the test procedure. If the CB is open throughout the tests, the Cold Load protection settings can be tested provided that the current is not allowed to fall below the level of the *Reduced Current Level* for more than the *Reduced Current Time* during testing. It may be convenient to set the *Reduced Current* setting to Disabled for the duration of the test. The Cold Load Active output is provided and can be used as an indication during testing.

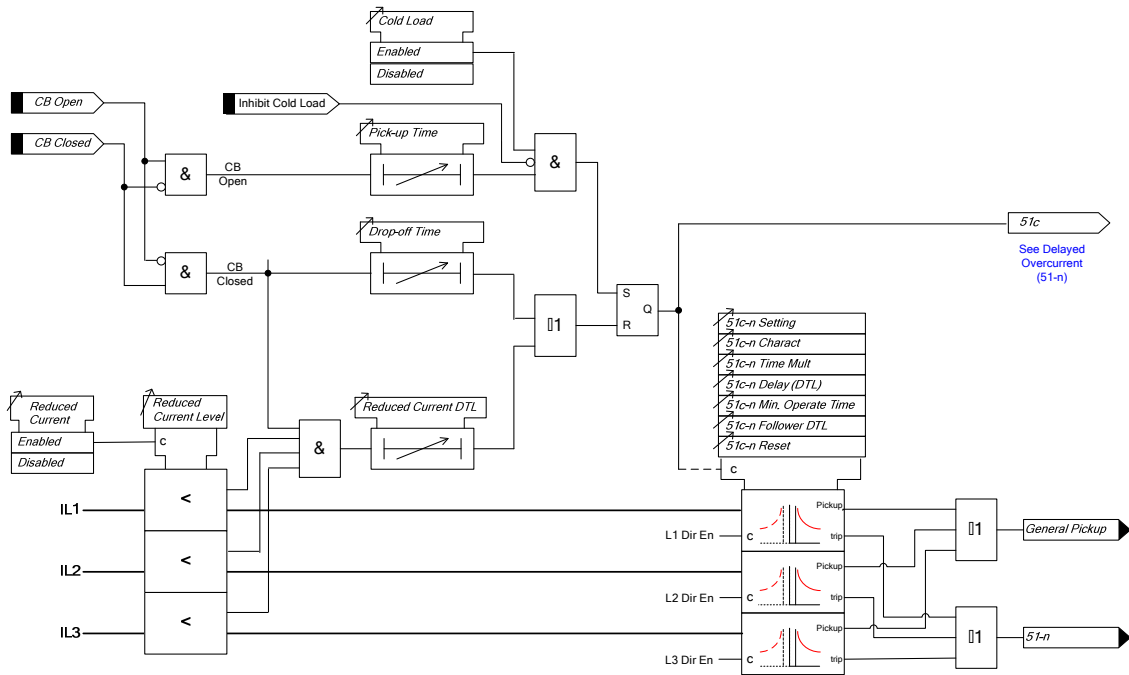

Figure 2-5 Cold Load Logic diagram

Ensure that the *Cold load active* is not raised. This can be reset by CB closed for more than the Cold Load *Drop-off Time* or current less than the *Reduced Current Level* for greater than the *Reduced Current Time*. Check the Cold Load *Pick-up Delay* by applying or simulating CB Open. Measure the time delay before *Cold Load Active* is raised. Apply current above the *Reduced Current Level* if this functionality is Enabled before applying CB Closed. Measure the time for *Cold Load Active* to reset.

2.4.1 Inverse Time Overcurrent (51C)

It will be advantageous to map the function being tested to temporarily drive the relevant Pickup output in the *Pickup Config* sub-menu in the *Output Config* menu as this will allow the Pickup led to operate for the function.

Gradually increase current until Pickup LED operates.

Apply 2x setting current and record operating time,

Apply 5x setting current and record operating time.

Compare to calculated values for operating times

P.U. D.O. & TIMING TESTS	Ph.	Dir	Char. (NI EI VI LTI, DTL)	Is (A)	TM	Operate Current			Operate Time		
						P.U. (Amps)	D.O. (Amps)	Tol	2 x Is (sec)	5 x Is (sec)	Tol
	IL1(Ia)										
	IL2(Ib)										
	IL3(Ic)										

Calculated Timing values in seconds for TM =1.0

Curve	2 xls	5 xls
IEC-NI	10.03	4.28
IEC-VI	13.50	3.38
IEC-EI	26.67	3.33
IEC-LTI	120.00	30.00
ANSI-MI	3.80	1.69
ANSI-VI	7.03	1.31
ANSI-EI	9.52	1.30

Note that the operate time may be subject to the *Minimum op time* setting for the element and/or may have a *Follower DTL* applied.

2.4.1.1 ANSI Reset

If the element is configured as an ANSI characteristic, it may have a reset delay applied. If ANSI reset is selected for an IEC characteristic element, the reset will be instantaneous.

ANSI reset times from operated condition to fully reset are as follows for zero applied current and TM = 1.0. The reset curve characteristic type and TM is defined by the operating characteristic.

Curve	Fully operated to reset with Zero current applied & TM=1 (secs)
ANSI-MI	4.85
ANSI-VI	21.6
ANSI-EI	29.1

Apply current in the following sequence, a) 2x setting for a time to ensure element operation, b) Zero current for the reset time above (xTM), c) 2x setting for a time to ensure element operation. Check that the second operation (c) is similar to the first (a) and in line with the expected operate time for the element at this current level.

Repeat the test with the reset time (b) reduced to 50% of the previous value. Ensure that the second operate time (c) is 50% of the first (a) operate time.

Operate time (expected)	Reset time (calculated)	Operate time (measured)	50% Reset Time (calculated)	50% operate time (calculated)	50% operate time (measured)
		First test (c)			Second Test (c)

Check correct indication, trip output, alarm contacts, waveform record.

2.4.1.2 IEC Reset

If the element is configured as an IEC characteristic, it may have an IEC (decaying) reset delay applied. If IEC reset is selected for an IEC characteristic element, the reset will be instantaneous.

IEC reset times from operated condition to fully reset are as follows for zero applied current and Time multiplier (TM) = 1.0. The reset curve characteristic type and TM is defined by the operating characteristic.

Curve	Fully operated to reset with Zero current applied & TM=1 (secs)
IEC-NI	9.7
IEC-VI	43.2
IEC-EI	58.2
IEC-LTI	80

Apply current in the following sequence, a) 2x setting for a time to ensure element operation, b) Zero current for the reset time above (xTM), c) 2x setting for a time to ensure element operation. Check that the second operation (c) is similar to the first (a) and in line with the expected operate time for the element at this current level.

Repeat the test with the reset time (b) reduced to 50% of the previous value. Ensure that the second operate time (c) is 50% of the first (a) operate time.

Operate time (expected)	Reset time (calculated)	Operate time (measured)	50% Reset Time (calculated)	50% operate time (calculated)	50% operate time (measured)
		First test (c)			Second Test (c)

2.4.1.3 Element Blocking

The 51c Overcurrent elements can be blocked by Binary Input Inhibit. This functionality should be checked.

Element	BI Inhibits
51c	

2.5 Directional Earth Fault Polarity Check (67N)

Derived Earth Fault, Measured Earth Fault and Sensitive Earth Fault elements can be set as directional. These are polarised from residual voltage, calculated from the 3 phase voltage inputs or the 3Vo input depending on the **Phase Voltage Config** setting in the **CT/VT Config** menu.

The relay Char Angle setting is the Characteristic Phase angle of the fault impedance i.e. the phase angle of the fault current with respect to the voltage driving the current. The earth fault functions are polarised from the residual voltage which is in anti-phase with the fault voltage for a single-phase to earth fault. Care is required when testing by secondary injection with regard to current and voltage polarity.

To simulate an earth fault on a relay with 3 phase-phase or 3 phase-neutral connected voltage inputs, defined by the **Phase Voltage Config** setting of **Van, Vbn, Vcn** or **Va, Vb, Vc**, proceed as follows. Balanced 3P voltage should first be applied, then the phase-neutral voltage magnitude on the faulted phase should be reduced in magnitude with no change in phase angle to produce V_{res} and simulate the fault. The fault current, on the faulted phase only, should be set at the MTA with respect to the phase-neutral voltage on the faulted phase, e.g. for a relay setting of -15° , set the phase current to lag the ph-n voltage by 15° .

Alternatively, a single phase voltage source can be used in the above test. The polarity of this voltage, applied to the faulted phase-neutral alone, must be reversed to produce the same residual voltage (V_{res}) phase direction as that produced by the 3P voltage simulation described above.

For the **Phase Voltage Config** of **Vab, Vbc, Vo**, the single phase voltage applied to the Vo input is used as the polarising quantity. The inversion is once again required since this input is designed to measure the residual voltage directly, as produced by an 'open delta VT' arrangement. The current must be set at the MTA with respect to the inversion of this voltage. e.g. for a relay setting of -15° , the phase current must lag the (V_o+180°) voltage by 15° , i.e. if V_o is set at 180° , set I_{ph} at -15° .

If the Pickup of one directional Earth Fault element is mapped to an LED, this can be used to check directional boundaries for pickup and drop-off as the current phase angle is increased and decreased. Note that the Derived Earth Fault, Measured Earth Fault and Sensitive Earth Fault have separate directional settings and must be tested individually.

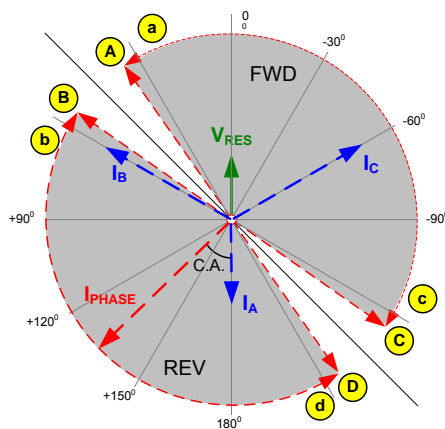

The diagram opposite shows a Phase A – Earth fault.

Apply residual voltage either directly to input or by reducing voltage of faulted phase.

Adjust the phase angle of the phase current relative to the voltage:

Verify directional pick-up and drop off at points A, B, C and D

Alternatively,

Verify correct directional indication at points a, b, c and d (C.A. $+75^\circ$, $+95^\circ$, -75° , -95°)

Figure 2-6 Directional Earth Fault Boundary System Angles

2.6 Derived Earth Fault (67/50N, 67/51N)

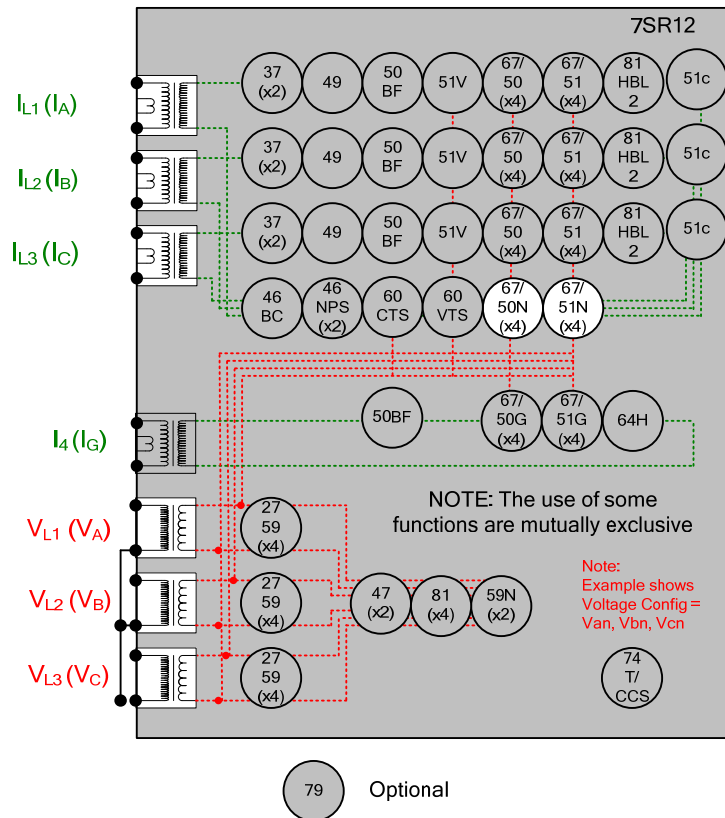

Figure 2-7 Derived Earth Fault

Voltage Inputs:	V_{L1} (V_A), V_{L2} (V_B), V_{L3} (V_C)
Current Inputs:	I_{L1} (I_A), I_{L2} (I_B), I_{L3} (I_C)
Disable:	37, 46, 49, 60CTS, 50CBF, 60CTS, 46BC, 79
Map Pickup LED:	51N-n/50N-n - Self Reset

Other protection functions may overlap with these functions during testing, it may be useful to disable some functions to avoid ambiguity. Derived EF, Measured EF Sensitive EF & Restricted EF protections can be Enabled/Disabled individually or as groups in the 'Function Config' menu.

Derived EF elements can be separated from Measured/Sensitive EF by arrangement of the secondary injection circuit by shorting/disconnecting I_4 Input.

If any of these elements are defined as directional the correct voltage phase direction will be required to produce an operation of those elements.

2.6.1 Directional Polarity

See section Directional Earth Fault Polarity Check above for testing details.

MTA	Forward				Reverse			
	Lag (point C)		Lead (point A)		Lead(point B)		Lag (point D)	
	Pick-up	Drop-off	Pick-up	Drop-off	Pick-up	Drop-off	Pick-up	Drop-off
.....	MTA-85		MTA+85		MTA-85		MTA-85	
Derived EF								

2.6.2 Definite Time Overcurrent (50N)

If DTL setting is small, gradually increase current until element operates.

If DTL is large apply 0.9x setting, check for no operation, apply 1.1x setting, check operation

Apply 2x setting current if possible and record operating time

Check correct indication, trip output, alarm contacts, waveform record.

Note that these elements can be set to directional.

Phase	Dir	Is (Amps)	DTL (sec)	P.U. Current Amps	Operate Time 2 x Is	NOTES
E						

If VTS action is set to BLOCK, this option should be tested. Apply balanced voltage and current. Reduce a-phase voltage to cause a VTS condition. Increase 3P current and check that the element does not operate.

If VTS action is set to Non-Directional, this option should be tested. Apply balanced voltage and current. Reduce a-phase voltage to cause a VTS condition. Increase a-phase current and check that the element operates at its normal setting. Reverse the voltage phase direction whilst checking that the element does not reset.

2.6.3 Inverse Time Overcurrent (51N)

It will be advantageous to map the function being tested to temporarily drive the relevant Pickup output in the *Pickup Config* sub-menu in the *Output Config* menu as this will allow the Pick-up led to operate for the function.

Gradually increase current until Pickup LED operates.

Apply 2x setting current and record operating time,

Apply 5x setting current and record operating time.

Compare to calculated values for operating times.

P.U. D.O. & TIMING TESTS	Ph.	Dir	Char. (NI EI VI LTI, DTL)	Is (A)	TM	Operate Current			Operate Time		
						P.U. (Amps)	D.O. (Amps)	Tol	2 x Is (sec)	5 x Is (sec)	Tol
	E										

Calculated Timing values in seconds for TM =1.0

Curve	2 xls	5 xls
IEC-NI	10.03	4.28
IEC-VI	13.50	3.38
IEC-EI	26.67	3.33
IEC-LTI	120.00	30.00
ANSI-MI	3.80	1.69
ANSI-VI	7.03	1.31
ANSI-EI	9.52	1.30

Note that the operate time may be subject to the *Minimum op time* setting for the element and/or may have a *Follower DTL* applied.

2.6.3.1 Element Blocking

The Derived Earth Fault elements can be blocked by Binary Input Inhibit, VT Supervision and Inrush Detector operation. The Characteristic can be made non-directional by VT Supervision. This functionality should be checked.

Element	BI Inhibits	VTS action	Inrush Detector
51N-1			
51N-2			
51N-3			
51N-4			
50N-1			
50N-2			
50N-3			
50N-4			

2.6.3.2 ANSI Reset

If the element is configured as an ANSI characteristic, it may have a reset delay applied. If ANSI reset is selected for an IEC characteristic element, the reset will be instantaneous.

ANSI reset times from operated condition to fully reset are as follows for zero applied current and $TM = 1.0$. The reset curve characteristic type and TM is defined by the operating characteristic.

Curve	Fully operated to reset with Zero current applied & $TM=1$ (secs)
ANSI-MI	4.85
ANSI-VI	21.6
ANSI-EI	29.1

Apply current in the following sequence, a) 2x setting for a time to ensure element operation, b) Zero current for the reset time above (xTM), c) 2x setting for a time to ensure element operation. Check that the second operation (c) is similar to the first (a) and in line with the expected operate time for the element at this current level.

Repeat the test with the reset time (b) reduced to 50% of the previous value. Ensure that the second operate time (c) is 50% of the first (a) operate time.

Operate time (expected)	Reset time (calculated)	Operate time (measured)	50% Reset Time (calculated)	50% operate time (calculated)	50% operate time (measured)
		First test (c)			Second Test (c)

Check correct indication, trip output, alarm contacts, waveform record.

2.6.3.3 IEC Reset

If the element is configured as an IEC characteristic, it may have an IEC (decaying) reset delay applied. If IEC reset is selected for an IEC characteristic element, the reset will be instantaneous.

IEC reset times from operated condition to fully reset are as follows for zero applied current and Time multiplier (TM) = 1.0. The reset curve characteristic type and TM is defined by the operating characteristic.

Curve	Fully operated to reset with Zero current applied & $TM=1$ (secs)
IEC-NI	9.7
IEC-VI	43.2
IEC-EI	58.2
IEC-LTI	80

Apply current in the following sequence, a) 2x setting for a time to ensure element operation, b) Zero current for the reset time above (xTM), c) 2x setting for a time to ensure element operation. Check that the second operation (c) is similar to the first (a) and in line with the expected operate time for the element at this current level.

Repeat the test with the reset time (b) reduced to 50% of the previous value. Ensure that the second operate time (c) is 50% of the first (a) operate time.

Operate time (expected)	Reset time (calculated)	Operate time (measured)	50% Reset Time (calculated)	50% operate time (calculated)	50% operate time (measured)
		First test (c)			Second Test (c)

2.7 Measured Earth fault (67/50G,67/51G)

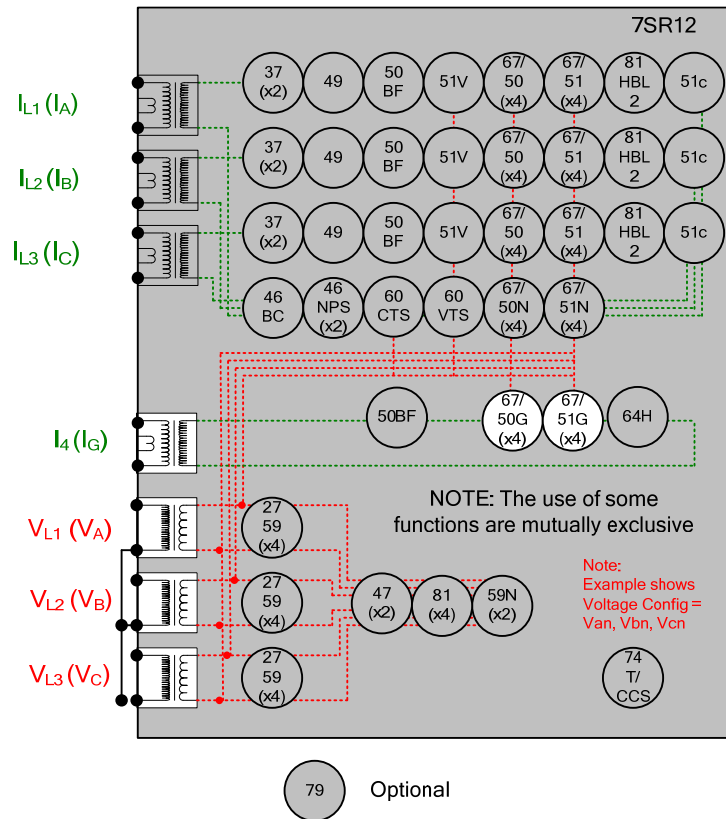

Figure 2-8 Measured Earth Fault

Voltage Inputs:	V_{L1} (V_A), V_{L2} (V_B), V_{L3} (V_C) for directional elements
Current Inputs:	I_4 (I_G)
Disable:	50CBF, 79
Map Pickup LED:	51G-n/50G-n - Self Reset

Other protection functions may overlap with these functions during testing, it may be useful to disable some functions to avoid ambiguity. Derived EF, Measured EF, Sensitive EF & Restricted EF protections can be Enabled/Disabled individually or as groups in the 'Function Config' menu.

Measured EF elements can be separated from Derived EF and Sensitive EF by secondary injection of current through the I_4 input circuit only.

If any of these elements are defined as directional the correct voltage phase direction will be required to produce an operation of those elements.

2.7.1 Directional Polarity

See section Directional Earth Fault Polarity Check above for testing details.

MTA	Forward				Reverse			
	Lag (point C)		Lead (point A)		Lead(point B)		Lag (point D)	
	Pick-up	Drop-off	Pick-up	Drop-off	Pick-up	Drop-off	Pick-up	Drop-off
.....	MTA-85		MTA+85		MTA-85		MTA-85	
Measured EF								

2.7.2 Definite Time Overcurrent (67/50G)

If DTL setting is small, gradually increase current until element operates.

If DTL is large apply 0.9x setting, check for no operation, apply 1.1x setting, check operation

Apply 2x setting current if possible and record operating time

Phase	Dir.	Is (Amps)	DTL (sec)	P.U. Current Amps	Operate Time 2 x Is	NOTES
I ₄						

Check correct indication, trip output, alarm contacts, waveform record.

Note that these elements can be set to directional.

If VTS action is set to BLOCK, this option should be tested. Apply balanced voltage and current. Reduce a-phase voltage to cause a VTS condition. Increase a-phase current and check that the element does not operate.

If VTS action is set to Non-Directional, this option should be tested. Apply balanced voltage and current. Reduce a-phase voltage to cause a VTS condition. Increase a-phase current and check that the element operates at its normal setting. Reverse the voltage phase direction whilst checking that the element does not reset.

2.7.3 Inverse Time Overcurrent (67/51G)

It will be advantageous to map the function being tested to temporarily drive the relevant Pickup output in the *Pickup Config* sub-menu in the *Output Config* menu as this will allow the Pick-up led to operate for the function.

Gradually increase current until Pickup LED operates.

Apply 2x setting current and record operating time,

Apply 5x setting current and record operating time.

Compare to calculated values for operating times

P.U. D.O. & TIMING TESTS	Ph.	Dir	Char. (NI EI VI LTI, DTL)	Is (A)	TM	Operate Current			Operate Time		
						P.U. (Amps)	D.O. (Amps)	Tol	2 x Is (sec)	5 x Is (sec)	Tol
		I ₄									

Calculated Timing values in seconds for TM =1.0

Curve	2 xls	5 xls
IEC-NI	10.03	4.28
IEC-VI	13.50	3.38
IEC-EI	26.67	3.33
IEC-LTI	120.00	30.00
ANSI-MI	3.80	1.69
ANSI-VI	7.03	1.31
ANSI-EI	9.52	1.30

Note that the operate time may be subject to the *Minimum op time* setting for the element and/or may have a *Follower DTL* applied.

If VTS action is set to BLOCK, this option should be tested. Apply balanced voltage and current. Reduce a-phase voltage to cause a VTS condition. Increase a-phase current and check that the element does not operate.

If VTS action is set to Non-Directional, this option should be tested. Apply balanced voltage and current. Reduce a-phase voltage to cause a VTS condition. Increase a-phase current and check that the element operates at its normal setting. Reverse the voltage phase direction whilst checking that the element does not reset.

2.7.3.1 Element Blocking

The Measured Earth Fault elements can be blocked by Binary Input Inhibit, VT Supervision and Inrush Detector operation. The Characteristic can be made non-directional by VT Supervision. This functionality should be checked.

Element	BI Inhibits	VTS action	Inrush Detector
51G-1			
51G-2			
51G-3			
51G-4			
50G-1			
50G-2			
50G-3			
50G-4			

2.7.3.2 ANSI Reset

If the element is configured as an ANSI characteristic, it may have a reset delay applied. If ANSI reset is selected for an IEC characteristic element, the reset will be instantaneous.

ANSI reset times from operated condition to fully reset are as follows for zero applied current and $TM = 1.0$. The reset curve characteristic type and TM is defined by the operating characteristic.

Curve	Fully operated to reset with Zero current applied & $TM=1$ (secs)
ANSI-MI	4.85
ANSI-VI	21.6
ANSI-EI	29.1

Apply current in the following sequence, a) 2x setting for a time to ensure element operation, b) Zero current for the reset time above (xTM), c) 2x setting for a time to ensure element operation. Check that the second operation (c) is similar to the first (a) and in line with the expected operate time for the element at this current level.

Repeat the test with the reset time (b) reduced to 50% of the previous value. Ensure that the second operate time (c) is 50% of the first (a) operate time.

Operate time (expected)	Reset time (calculated)	Operate time (measured)	50% Reset Time (calculated)	50% operate time (calculated)	50% operate time (measured)
		First test (c)			Second Test (c)

Check correct indication, trip output, alarm contacts, waveform record.

2.7.3.3 IEC Reset

If the element is configured as an IEC characteristic, it may have an IEC (decaying) reset delay applied. If IEC reset is selected for an IEC characteristic element, the reset will be instantaneous.

IEC reset times from operated condition to fully reset are as follows for zero applied current and Time multiplier (TM) = 1.0. The reset curve characteristic type and TM is defined by the operating characteristic.

Curve	Fully operated to reset with Zero current applied & $TM=1$ (secs)
IEC-NI	9.7
IEC-VI	43.2
IEC-EI	58.2
IEC-LTI	80

Apply current in the following sequence, a) 2x setting for a time to ensure element operation, b) Zero current for the reset time above (xTM), c) 2x setting for a time to ensure element operation. Check that the second operation (c) is similar to the first (a) and in line with the expected operate time for the element at this current level.

Repeat the test with the reset time (b) reduced to 50% of the previous value. Ensure that the second operate time (c) is 50% of the first (a) operate time.

Operate time (expected)	Reset time (calculated)	Operate time (measured)	50% Reset Time (calculated)	50% operate time (calculated)	50% operate time (measured)
		First test (c)			Second Test (c)

2.8 Sensitive Earth fault (67/50S,67/51S)

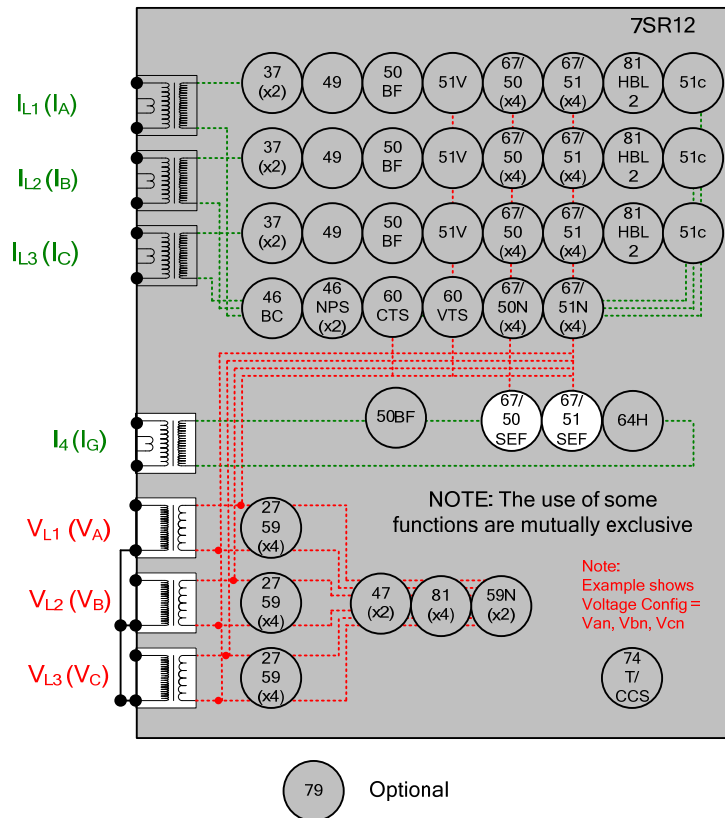

Figure 2-9 Sensitive Earth Fault

Voltage Inputs:	V_{L1} (V_A), V_{L2} (V_B), V_{L3} (V_C) for directional elements
Current Inputs:	I_4 (I_{SEF})
Disable:	64H, 50CBF, 79
Map Pickup LED:	51SEF-n/50SEF-n - Self Reset

Other protection functions may overlap with these functions during testing, it may be useful to disable some functions to avoid ambiguity. Derived EF, Sensitive EF & Restricted EF protections can be Enabled/Disabled individually or as groups in the 'Function Config' menu.

Sensitive EF elements can be separated from Derived EF by secondary injection of current through the I_4 input circuit only.

If any of these elements are defined as directional the correct voltage phase direction will be required to produce an operation of those elements.

The 67SEF elements will normally operate on the residual current through the I_4 input but can be set to operate on only the real (wattmetric) component of this current by setting *67SEF Ires Select* to *Ires Real*. If this option is selected, the residual current and voltage should be set in anti-phase during testing to so that the applied current is purely real and can be measured directly.

If *67SEF Wattmetric* is set to *Enabled*, the residual real power must also exceed the *67SEF Wattmetric Power* setting to permit SEF operation

2.8.1 Directional Polarity

See section Directional Earth Fault Polarity Check above for testing details.

If *67SEF Wattmetric* is set to *Enabled*, the residual real power must also exceed the *67SEF Wattmetric Power* setting to permit SEF operation. As the directional boundary is approached, the Wattmetric current, will by

definition reduce towards zero. It is therefore necessary to increase the residual current or to temporarily disable the Wattmetric function to allow the directional boundary to be tested.

If the 67SEF Compensated Network setting is set to Enabled, the directional boundaries will be extended to MTA+87° and MTA-87°.

MTA	Forward				Reverse			
	Lag (point C)		Lead (point A)		Lead (point B)		Lag (point D)	
	Pick-up	Drop-off	Pick-up	Drop-off	Pick-up	Drop-off	Pick-up	Drop-off
.....	MTA-85		MTA+85		MTA-85		MTA-85	
	
SEF								

2.8.2 Definite Time Overcurrent (50SEF)

If DTL setting is small, gradually increase current until element operates.

If DTL is large apply 0.9x setting, check for no operation, apply 1.1x setting, check operation

Apply 2x setting current if possible and record operating time

P.U. D.O. & TIMING TESTS	Ph.	Dir	Char. (NI EI VI LTI, DTL)	Is (A)	TM	Operate Current			Operate Time		
						P.U. (Amps)	D.O. (Amps)	Tol	2 x Is (sec)	5 x Is (sec)	Tol
		I ₄									

Check correct indication, trip output, alarm contacts, waveform record.

Note that these elements can be set to directional.

If VTS action is set to BLOCK, this option should be tested. Apply balanced voltage and current. Reduce a-phase voltage to cause a VTS condition. Increase a-phase current and check that the element does not operate.

If VTS action is set to Non-Directional, this option should be tested. Apply balanced voltage and current. Reduce a-phase voltage to cause a VTS condition. Increase a-phase current and check that the element operates at its normal setting. Reverse the voltage phase direction whilst checking that the element does not reset.

2.8.3 Wattmetric Protection

The Wattmetric Earth Fault protection requires that the SEF current setting is exceeded, the residual power setting is exceeded and the directional element operated, simultaneously.

During testing of the **67SEF Wattmetric power** setting it is essential that the current setting is also exceeded. This can usually be achieved by applying current which is above setting to the SEF input whilst applying single phase voltage, in anti-phase with the current, to any 1 phase to neutral voltage input. In this way, the wattmetric power is equal to the product of the applied current and applied voltage and can be adjusted by adjustment of the voltage magnitude.

Wattmetric Power Setting	Current Applied I _o	Dir	Operate Voltage V _o	Calculated Po I _o x V _o

During testing of the **67SEF Ires select** residual current setting it is essential that the wattmetric power setting is also exceeded. This can usually be achieved by applying the test current to the SEF input whilst applying a nominal single phase voltage, in anti-phase with the current, to all 3 phase to neutral voltage inputs. In this way, the wattmetric power is equal to the product of 3 times the applied voltage and the applied current and this should always be greater than the Wattmetric power setting.

2.8.4 Inverse Time Overcurrent (51SEF)

It will be advantageous to map the function being tested to temporarily drive the relevant Pickup output in the *Pickup Config* sub-menu in the *Output Config* menu as this will allow the Pick-up led to operate for the function.

Gradually increase current until Pickup LED operates.

Apply 2x setting current and record operating time,

Apply 5x setting current and record operating time.

Compare to calculated values for operating times

P.U. D.O. & TIMING TESTS	Ph.	Dir	Char. (NI EI VI LTI, DTL)	Is (A)	TM	Operate Current			Operate Time		
						P.U. (Amps)	D.O. (Amps)	Tol	2 x Is (sec)	5 x Is (sec)	Tol
	I ₄										

Calculated Timing values in seconds for TM =1.0

Curve	2 x Is	5 x Is
IEC-NI	10.03	4.28
IEC-VI	13.50	3.38
IEC-EI	26.67	3.33
IEC-LTI	120.00	30.00
ANSI-MI	3.80	1.69
ANSI-VI	7.03	1.31
ANSI-EI	9.52	1.30

Note that the operate time may be subject to the *Minimum op time* setting for the element and/or may have a *Follower DTL* applied.

If VTS action is set to BLOCK, this option should be tested. Apply balanced voltage and current. Reduce a-phase voltage to cause a VTS condition. Increase a-phase current and check that the element does not operate.

If VTS action is set to Non-Directional, this option should be tested. Apply balanced voltage and current. Reduce a-phase voltage to cause a VTS condition. Increase a-phase current and check that the element operates at its normal setting. Reverse the voltage phase direction whilst checking that the element does not reset.

2.8.4.1 Element Blocking

The Sensitive Earth Fault elements can be blocked by Binary Input Inhibit, VT Supervision and Wattmetric protection. The Characteristic can be made non-directional by VT Supervision. This functionality should be checked.

Element	BI Inhibits	VTS action
51SEF-1		
51SEF-2		
51SEF-3		
51SEF-4		
50SEF-1		

50SEF-2		
50SEF-3		
50SEF-4		

2.8.4.2 ANSI Reset

If the element is configured as an ANSI characteristic, it may have a reset delay applied. If ANSI reset is selected for an IEC characteristic element, the reset will be instantaneous.

ANSI reset times from operated condition to fully reset are as follows for zero applied current and $TM = 1.0$. The reset curve characteristic type and TM is defined by the operating characteristic.

Curve	Fully operated to reset with Zero current applied & $TM=1$ (secs)
ANSI-MI	4.85
ANSI-VI	21.6
ANSI-EI	29.1

Apply current in the following sequence, a) 2x setting for a time to ensure element operation, b) Zero current for the reset time above (xTM), c) 2x setting for a time to ensure element operation. Check that the second operation (c) is similar to the first (a) and in line with the expected operate time for the element at this current level.

Repeat the test with the reset time (b) reduced to 50% of the previous value. Ensure that the second operate time (c) is 50% of the first (a) operate time.

Operate time (expected)	Reset time (calculated)	Operate time (measured)	50% Reset Time (calculated)	50% operate time (calculated)	50% operate time (measured)
		First test (c)			Second Test (c)

Check correct indication, trip output, alarm contacts, waveform record.

2.8.4.3 IEC Reset

If the element is configured as an IEC characteristic, it may have an IEC (decaying) reset delay applied. If IEC reset is selected for an IEC characteristic element, the reset will be instantaneous.

IEC reset times from operated condition to fully reset are as follows for zero applied current and Time multiplier (TM) = 1.0. The reset curve characteristic type and TM is defined by the operating characteristic.

Curve	Fully operated to reset with Zero current applied & $TM=1$ (secs)
IEC-NI	9.7
IEC-VI	43.2
IEC-EI	58.2
IEC-LTI	80

Apply current in the following sequence, a) 2x setting for a time to ensure element operation, b) Zero current for the reset time above (xTM), c) 2x setting for a time to ensure element operation. Check that the second operation (c) is similar to the first (a) and in line with the expected operate time for the element at this current level.

Repeat the test with the reset time (b) reduced to 50% of the previous value. Ensure that the second operate time (c) is 50% of the first (a) operate time.

Operate time (expected)	Reset time (calculated)	Operate time (measured)	50% Reset Time (calculated)	50% operate time (calculated)	50% operate time (measured)
		First test (c)			Second Test (c)

2.9 Restricted Earth fault (64H)

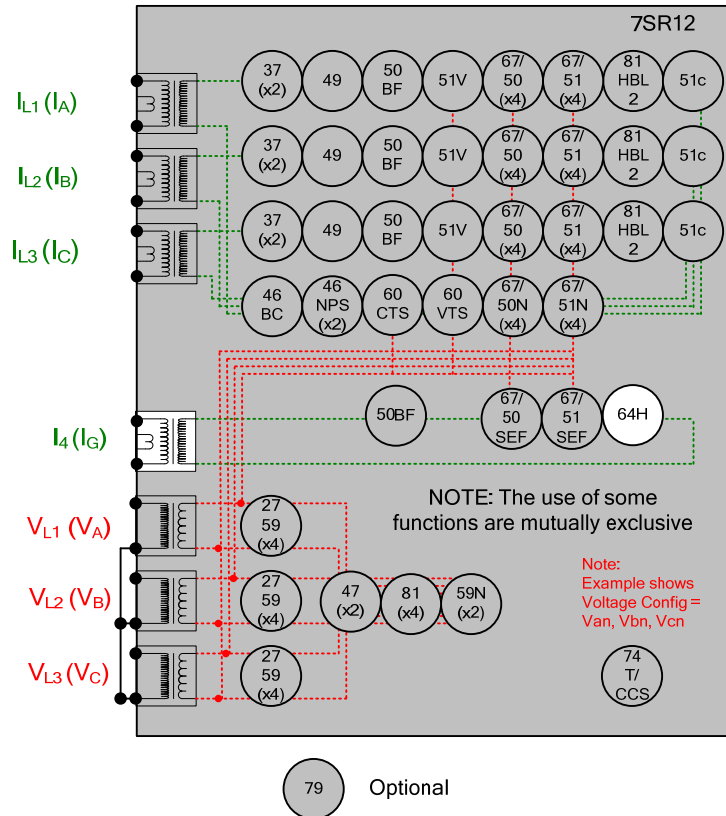

Figure 2-10 Restricted Earth Fault

Voltage Inputs:	n/a
Current Inputs:	I_4 (I_{REF})
Disable:	51SEF, 50SEF, 79
Map Pickup LED:	64H - Self Reset

The setting resistance should be measured and the value compared to that specified in the settings data. Both values should be recorded.

Settings Data Resistor Value	Measured

The high value of setting resistance R will often interfere with secondary current injection when using a digital test set. It is normal practice in these cases to short out the series resistor to allow testing, the shorting link should be removed after testing.

Since the DTL setting is generally small the pick-up setting can be tested by gradually increasing current until element operates. The relay should be disconnected from the current transformers for this test.

Apply 2x setting current if possible and record operating time

Phase	Is (Amps)	DTL (sec)	P.U. Current Amps	Tolerance	Operate Time 2 x Is	Tolerance
REF						

It is also desirable to check the operating voltage achieved with the setting resistor and all parallel CTs connected but de-energised. A higher capacity test set will be required for this test. Adequate current must be supplied to provide the magnetising current of all connected CTs. Precautions should be taken to ensure that no personnel are at risk of contact with any of the energised secondary wiring during the test.

Settings Data Voltage Setting	Measured

To complete testing of the REF requires primary injection through the phase and residual (REF) CT in series to simulate an out of zone fault and ensure stability of the relay. The test can then be repeated with the REF CT secondary connections reversed to prove operation.

2.9.1.1 Element Blocking

The Restricted Earth Fault element can be blocked by Binary Input Inhibit. This functionality should be checked.

Element	BI Inhibits
64H	

Check correct indication, trip output, alarm contacts, waveform record.

Check that any shorting links are removed after testing.

2.10 Negative Phase Sequence Overcurrent (46NPS)

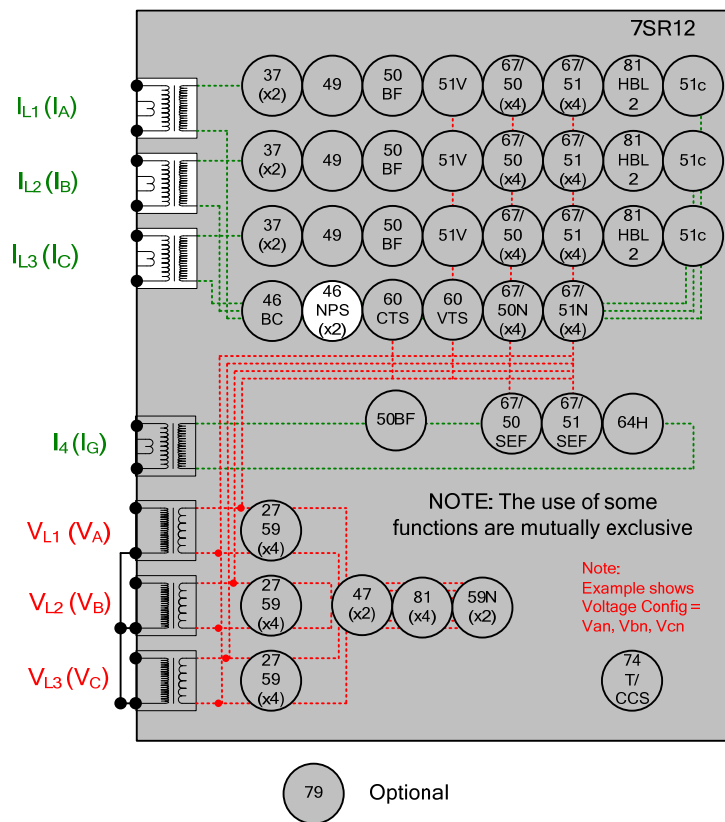

Figure 2-11 Negative Phase Sequence Overcurrent

Voltage Inputs:	n/a
Current Inputs:	$I_{L1} (I_A)$, $I_{L2} (I_B)$, $I_{L3} (I_C)$,
Disable:	51, 51V, 51C, 37, 49, 50CBF, 60CTS, 46BC
Map Pickup LED:	46IT/46DT - Self Reset

Where two NPS elements are being used with different settings, it is convenient to test the elements with the highest settings first. The elements with lower settings can then be tested without disabling the lower settings. The Thermal withstand limitations of the current inputs, stated in the Performance Specification should always be observed throughout testing.

NPS Overcurrent can be tested using a normal 3P balanced source. Two phase current connections should be reversed so that the applied balanced 3P current is Negative Phase Sequence.

2.10.1 Definite Time NPS Overcurrent (46DT)

If DTL setting is small, gradually increase current until element operates.

If DTL is large apply 0.9x setting, check for no operation, apply 1.1x setting, check operation

Apply 2x setting current if possible and record operating time

Phase	Is (Amps)	DTL (sec)	P.U. Current Amps	Tolerance	Operate Time 2 x Is	Tolerance
NPS						

Check correct indication, trip output, alarm contacts, waveform record.

2.10.2 Inverse Time NPS Overcurrent (46IT)

It will be advantageous to map the function being tested to temporarily drive the relevant Pickup output in the *Pickup Config* sub-menu in the *Output Config* menu as this will allow the Pick-up led to operate for the function.

Gradually increase current until Pickup LED operates.

Apply 2x setting current and record operating time,

Apply 5x setting current and record operating time.

Compare to calculated values for operating times

P.U. D.O. & TIMING TESTS	Ph.	Dir	Char. (NI EI VI LTI, DTL)	Is (A)	TM	Operate Current			Operate Time		
						P.U. (Amps)	D.O. (Amps)	Tol	2 x Is (sec)	5 x Is (sec)	Tol
	NPS										

Calculated Timing values in seconds for TM =1.0

Curve	2 x Is	5 x Is
IEC-NI	10.03	4.28
IEC-VI	13.50	3.38
IEC-EI	26.67	3.33
IEC-LTI	120.00	30.00
ANSI-MI	3.80	1.69
ANSI-VI	7.03	1.31
ANSI-EI	9.52	1.30

Note that the operate time may be subject to the *Minimum op time* setting for the element and/or may have a *Follower DTL* applied.

2.10.2.1 ANSI Reset

If the element is configured as an ANSI characteristic, it may have a reset delay applied. If ANSI reset is selected for an IEC characteristic element, the reset will be instantaneous.

ANSI reset times from operated condition to fully reset are as follows for zero applied current and $TM = 1.0$. The reset curve characteristic type and TM is defined by the operating characteristic.

Curve	Fully operated to reset with Zero current applied & $TM=1$ (secs)
ANSI-MI	4.85
ANSI-VI	21.6
ANSI-EI	29.1

Apply current in the following sequence, a) 2x setting for a time to ensure element operation, b) Zero current for the reset time above (xTM), c) 2x setting for a time to ensure element operation. Check that the second operation (c) is similar to the first (a) and in line with the expected operate time for the element at this current level.

Repeat the test with the reset time (b) reduced to 50% of the previous value. Ensure that the second operate time (c) is 50% of the first (a) operate time.

Operate time (expected)	Reset time (calculated)	Operate time (measured)	50% Reset Time (calculated)	50% operate time (calculated)	50% operate time (measured)
		First test (c)			Second Test (c)

2.10.2.2 Element Blocking

The NPS Overcurrent elements can be blocked by Binary Input Inhibit. This functionality should be checked.

Element	BI Inhibits
46IT	
46DT	

Check correct indication, trip output, alarm contacts, waveform record.

When testing is complete reinstate any of the disabled functions.

2.11 Undercurrent (37)

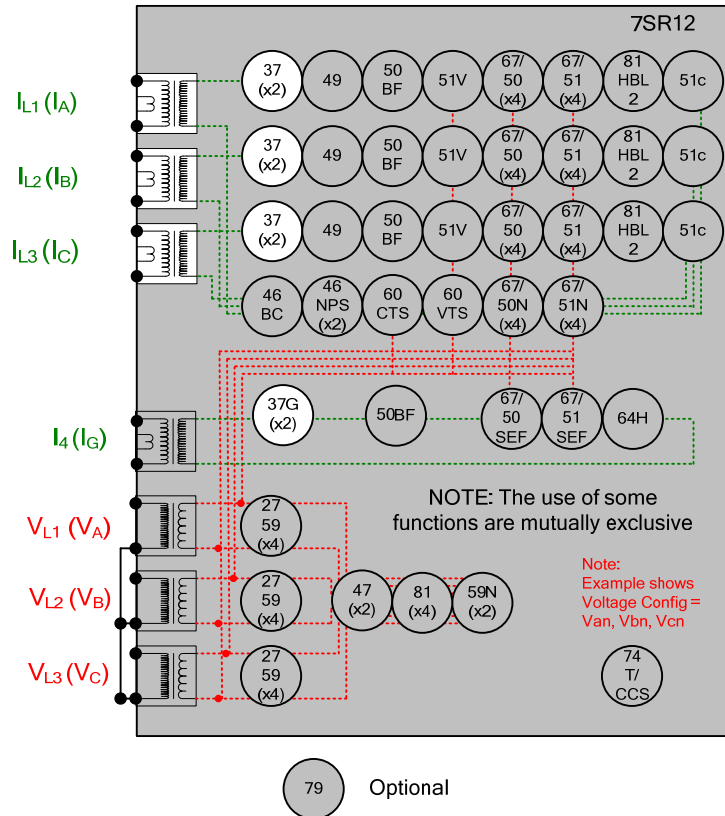

Figure 2-12 Undercurrent

Voltage Inputs:	n/a
Current Inputs:	I_{L1} (I_A), I_{L2} (I_B), I_{L3} (I_C), I_4
Disable:	51N, 51G, 46, 60CTS, 46BC
Map Pickup LED:	37-n - Self Reset
Undercurrent Guard:	As required
Undercurrent start:	Any or ALL

If two Undercurrent 37 elements are used with different settings, it is convenient to test the element with the lowest setting first. The higher setting element can then be tested without interference from the other element.

Apply 3Phase balanced current or single phase current on the single pole relay models and earth fault function 37G/37SEF, at a level above the Undercurrent 37-n setting until the element resets. Check operation with start option set to ANY phase and repeat with it set to operate for ALL phases.

If DTL setting is small, gradually reduce any phase current in turn until element operates.

If DTL is large apply 1.1x setting, check for no operation, apply 0.9x setting, check operation

Testing of this element phase by phase may cause inadvertent operation of the 46 NPS Overcurrent elements.

Apply 0.5x setting current and record operating time

Phase	I _s (Amps)	DTL (sec)	P.U. Current Amps	Tolerance	Operate Time 0.5 x I _s	Tolerance
I _{L1} (I _A)						
I _{L2} (I _B)						
I _{L3} (I _C)						
I ₄ (I _G)						

2.11.1.1 Element Blocking

The Undercurrent elements can be blocked by Binary Input Inhibit. This functionality should be checked.

Element	BI Inhibits
37-1	
37-2	
37G-1 or 37SEF-1	
37G-2 or 37SEF-2	

2.11.1.2 Element Blocking from current guard

The elements can be blocked by undercurrent guard function. This functionality should be checked.

Element	Guard Setting	Blocked
37-1		
37-2		

Check correct phase indication, trip output, alarm contacts, waveform record.

2.12 Thermal Overload (49)

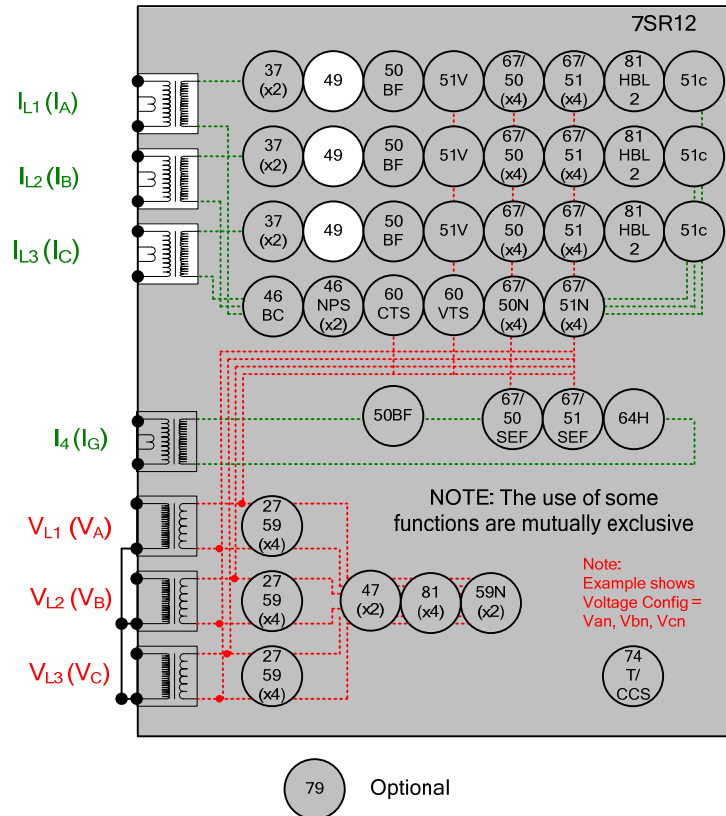

Figure 2-13 Thermal Overload

Voltage Inputs:	n/a
Current Inputs:	I_{L1} (I _A), I_{L2} (I _B), I_{L3} (I _C),
Disable:	51, 50, 37, 50CBF
Map Pickup LED:	49Alarm

The current can be applied from a 3P balanced supply or phase by phase from a 1P supply. Alternatively the 3 phase current inputs can be connected in series and injected simultaneously from a single 1P source.

The Thermal Overload Setting and Time Constant Setting can be considered together to calculate the operating time for a particular applied current.

The following table lists operate times for a range of Time Constant Settings for an applied current of 2x the Thermal Overload setting. Ensure that the thermal rating of the relay is not exceeded during this test.

Time Constant (mins)	Operate Time (sec)
1	17.3
2	34.5
3	51.8
4	69
5	86.3
10	173
15	259
20	345
25	432
30	51.8
50	863
100	1726

The Thermal State must be in the fully reset condition in order to measure the operate time correctly. This can be achieved by setting change in the Thermal protection settings menu or by pressing the Test/Reset button when the Thermal Meter is shown in the Instruments Mode.

Reset the thermal State then apply 2x the Overload Setting current.

Calculated Operate Time (s)	Measured Operate Time (s)

If the Thermal Overload Capacity Alarm is used, this can be tested by monitoring the Thermal Capacity in the instruments menu. If the Thermal time constant is longer than a few minutes, this can be assessed during the timing test above. If the Time Constant is less than a few minutes, a lower multiple of current will be required such that the rate of capacity increase is slowed to allow monitoring of the instrument to be accurate.

Capacity Alarm Setting	Measured

2.12.1.1 Element Blocking

The Thermal element can be blocked by Binary Input Inhibit. This functionality should be checked.

Element	BI Inhibits
49	

2.13 Over/Under Voltage

2.13.1 Phase Under/Over Voltage (27/59)

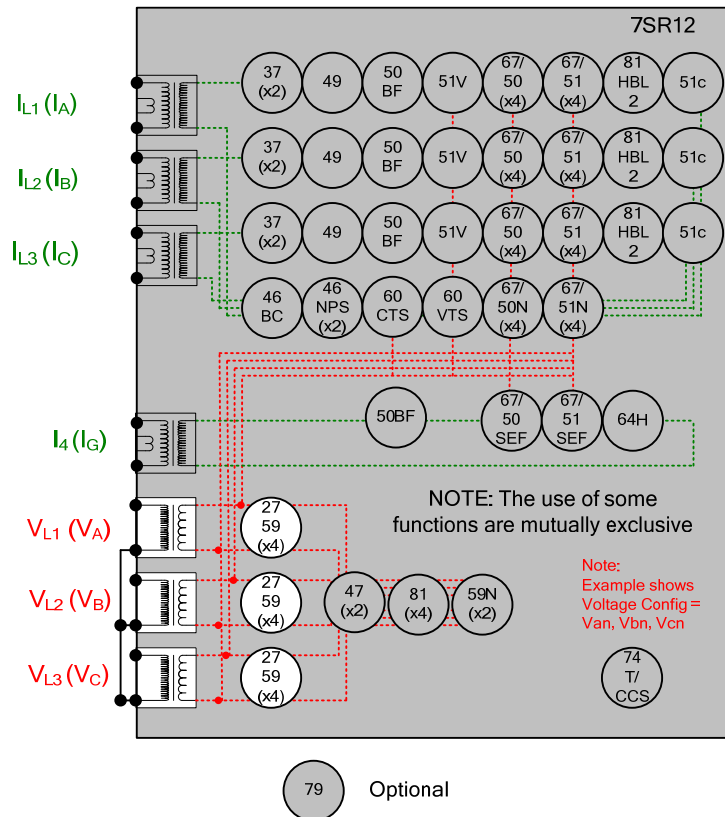

Figure 2-14 Phase Under/Over Voltage

Voltage Inputs:	V_{L1} (V_A), V_{L2} (V_B), V_{L3} (V_C)
Current Inputs:	n/a apply zero current to stabilize other functions
Disable:	47, 59N, 60VTS
Map Pickup LED:	27/59-n - Self Reset

Where more than one Undervoltage (27) elements are being used with different settings, it is convenient to test the elements with the lowest settings first. The elements with higher settings can then be tested without disabling the lower settings.

Note that if the voltage is reduced below the 27UVG setting, the function may be blocked. VTS operation may also block the 27 Undervoltage function. Current inputs are not normally required to stabilise the relay during voltage element testing.

If the 'O/P Phases' is set to 'All', the voltage on all phases must be reduced simultaneously. Otherwise the 3 phases should be tested individually. If the DTL is short, starting from nominal voltage, slowly decrease the applied 3P or VL1 test voltage until the Pickup LED (temporarily mapped) is lit. Record the operate voltage. The LED should light at setting Volts +/-5%. Slowly increase the input voltage until the LED extinguishes. Record the reset voltage to check the 'Hysteresis' setting. If the DTL is long, the operate level level should be checked by applying a voltage of 90% of setting voltage. Check Hysteresis by resetting element to the operate level setting plus the hysteresis setting.

Connect the relevant output contact(s) to stop the test set. Step the applied voltage to a level below the setting. The test set should be stopped at the operate time setting +/-5%

Test inputs VL2 and VL3 by repeating the above if necessary.

When testing is complete reinstate any of the disabled functions.

Where more than one overvoltage (59) elements are being used with different settings, it is convenient to test the elements with the highest settings first. The elements with lower settings can then be tested without disabling the higher settings.

If the 'O/P Phases' is set to 'All', the voltage on all phases must be increased simultaneously. Otherwise the 3 phases should be tested individually. If the DTL setting is short, starting from nominal voltage, slowly increase the applied 3P or VL1 test voltage until the Pickup LED (temporarily mapped) is lit. The LED should light at setting Volts +/-5% Decrease the input voltage to nominal Volts and the LED will extinguish. Record the reset voltage to check the 'Hysteresis' setting. If the DTL setting is long, the operate level can be checked by applying 100% of setting to cause operation followed by setting minus the Hysteresis setting to cause reset.

Connect the relevant output contact(s) to stop the test set. Step the applied voltage to a level above the setting. The test set should be stopped at the operate time setting +/-5%

Test inputs VL2 and VL3 by repeating the above if necessary.

Phase	27/59 setting (Volts)	U/O	DTL (sec)	Hyst.	D.O. (calculated)	P.U. Volts	D.O Volts	Op. Time 2x Vs (OV) 0.5x Vs (UV)	UV Guard	Tol
V ₁ (V _A)										
V ₂ (V _B)										
V ₃ (V _C)										

2.13.1.1 Element Blocking

The NPS Overcurrent elements can be blocked by Binary Input Inhibit and VT Supervision. This functionality should be checked.

Element	BI Inhibits	VT Supervision
27/59-1		
27/59-2		
27/59-3		
27/59-4		

When testing is complete reinstate any of the disabled functions.

2.13.2 Undervoltage Guard (27/59UVG)

If any 27 Undervoltage element is set to be inhibited by the 27 Undervoltage Guard element, this function should be tested.

Connect the test voltage inputs to suit the installation wiring diagram utilising any test socket facilities available. It may be useful to temporarily map an LED as 'General Pickup' to assist during testing. 27UVG operation will reset the General Pickup if no other element is operated. This LED should not be set as 'Hand Reset' in the Output matrix.

Starting from nominal voltage, apply a step decrease to the applied voltage to a level below the 27 Undervoltage setting but above the 27UVG setting such that an Undervoltage element operation occurs. Slowly reduce the applied voltage until the 27 Undervoltage element resets, this can be detected by the General Pickup LED reset if no other element is operated (this includes any Undervoltage element which is not UV Guarded).

Phase	Vs (Volts)	Tol	V element Used for test	Blocked Volts	NOTES
UVG					

2.13.3 NPS Overvoltage (47)

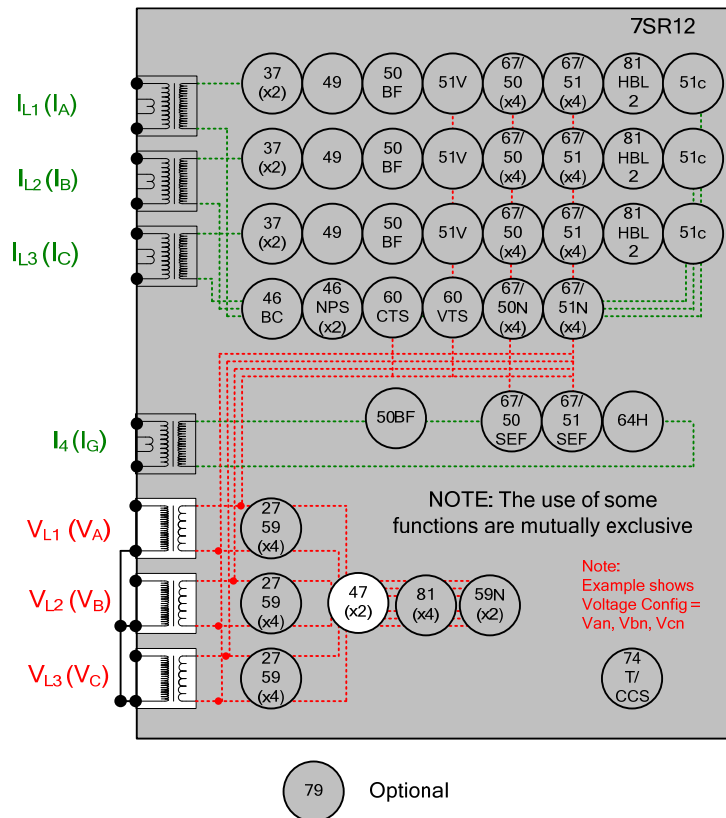

Figure 2-15 NPS Overvoltage

- Voltage Inputs: V_{L1} (V_A), V_{L2} (V_B), V_{L3} (V_C)
- Current Inputs: n/a apply zero current to stabilize other functions
- Disable: 27/59, 59N, 60VTS
- Map Pickup LED: 47-n - Self Reset

Where two NPS elements are being used with different settings, it is convenient to test the elements with the highest settings first. The elements with lower settings can then be tested without disabling the lower settings.

NPS Overvoltage can be tested using a normal 3P balanced source. Two phase voltage connections should be reversed so that the applied balanced 3P voltage is Negative Phase Sequence.

If the 47-n delay is small, gradually increased the applied balanced 3P voltage until element operates.

If DTL is large apply 0.9x setting, check for no operation, apply 1.1x setting, check operation

Apply 2x setting current if possible and record operating time

Phase	27/59 setting (Volts)	U/O	DTL (sec)	Hyst.	D.O. (calculated)	P.U. Volts	D.O Volts	Op. Time 2x Vs	Tolerance
NPS									

2.13.3.1 Element Blocking

The NPS Overvoltage element can be blocked by Binary Input Inhibit. This functionality should be checked.

Element	BI Inhibits
47-1	
47-2	

Check correct indication, trip output, alarm contacts, waveform record.

2.13.4 Neutral Overvoltage (59N)

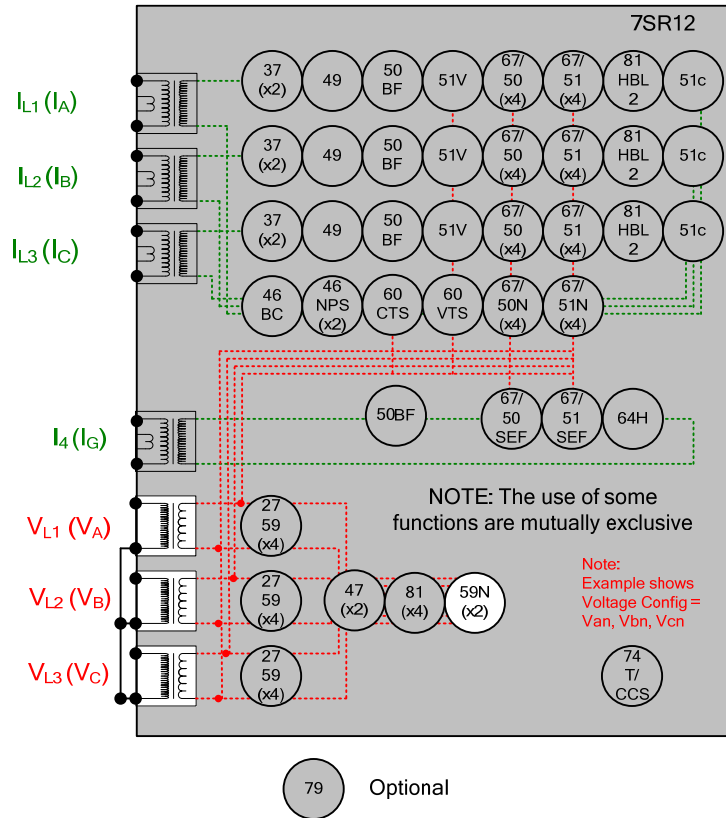

Figure 2-16 Neutral Overvoltage

- Voltage Inputs: V_{L1} (V_A), V_{L2} (V_B), V_{L3} (V_C)
- Current Inputs: n/a apply zero current to stabilize other functions
- Disable: 27/59, 47, 60VTS
- Map Pickup LED: 59N-n - Self Reset

The voltage source for the Neutral Overvoltage 59N function is V_n , calculated from the applied 3 phase voltage inputs. To test, apply test voltage to one phase input.

2.13.5 Definite Time (59NDT)

- If DTL setting is small, gradually increase single phase voltage until element operates.
- If DTL is large apply 0.9x setting, check for no operation, apply 1.1x setting, check operation
- Apply 2x setting voltage if possible and record operating time

Phase	Vs (Volts)	DTL (sec)	P.U. Current Volts	Operate Time 2 x Vs	Tolerance
E					

Check correct indication, trip output, alarm contacts, waveform record.

2.13.6 Inverse Time (59NIT)

It will be advantageous to map the function being tested to temporarily drive the relevant Pickup output in the *Pickup Config* sub-menu in the *Output Config* menu as this will allow the Pick-up led to operate for the function.

Gradually increase voltage until Pickup LED operates.

Apply 2x setting voltage and record operating time,

Apply a higher multiple of setting voltage and record operating time.

Compare to calculated values for operating times from:

$$t_{op}(\text{sec}) = M \left[\frac{1}{\left[\frac{V_n}{V_s} \right] - 1} \right]$$

Where M = Time multiplier and V_n/V_s = multiple of setting.

P.U. D.O. & TIMING TESTS	Ph.	Vs (V)	TM	Operate Voltage			Operate Time		
				P.U. (Volts)	D.O. (Volts)	Tol	2 x Vs (sec)	x Vs (sec)	Tol
E									

2.13.6.1 Element Blocking

The Neutral Overvoltage elements can be blocked by Binary Input Inhibit. This functionality should be checked.

Element	BI Inhibits
59NIT	
59NDT	

Check correct indication, trip output, alarm contacts, waveform record.

When testing is complete reinstate any of the disabled functions.

2.14 Under/Over Frequency (81)

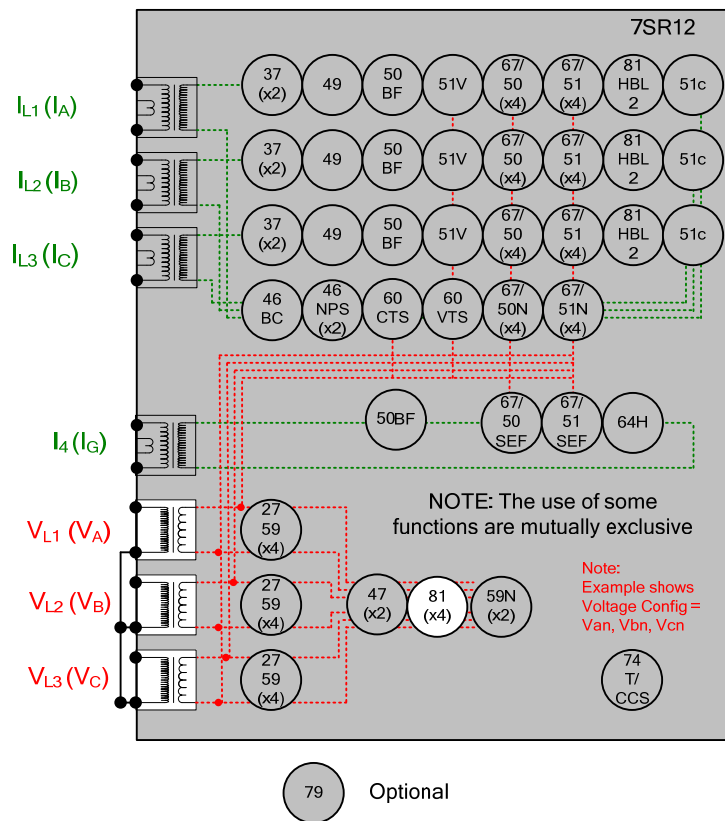

Figure 2-17 Under/Over Frequency

Voltage Inputs:	V_{L1} (V_A), V_{L2} (V_B), V_{L3} (V_C)
Current Inputs:	n/a apply zero current to stabilize other functions
Disable:	
Map Pickup LED:	81-n - Self Reset

This function can be tested by application of 1P or 3P voltage. For Over-frequency, the elements with the highest setting should be tested first and for Under-frequency the elements with the lowest settings should be tested first. The elements with other settings can then be tested without need to disable the elements already tested. Note that the relay is designed to track the gradual changes in power system frequency and that sudden step changes in frequency during testing do not reflect normal system operation. Normal 'instantaneous' operation of the frequency element is 140-175ms in line with the Performance Specification. Application of sudden step changes to frequency can add additional delay which can produce misleading test results.

Gradually increase/decrease applied voltage frequency until 81-n operation occurs. Elements set for more extreme frequency fluctuation should be tested first with lesser elements disabled.

If the 81-n Delay setting is long it will be advantageous to map the function to temporarily drive the relevant Pickup output in the *Pickup Config* sub-menu in the *Output Config* menu as this will allow the Pick-up led to operate for the function. If the delay setting is short the operation of the element can be easily checked directly.

The frequency should then be gradually decreased/increased until the element resets. The reset frequency can be used to check the Hysteresis setting.

If the element is set as **81-n U/V Guarded**, The applied voltage must be above the **81 UV Guard Setting** in the **U/O Frequency** menu.

Apply setting frequency +0.5Hz for Over-frequency or -0.5Hz for Under-frequency and record operating time.

Starting with the element in the operated condition, gradually increase or decrease the applied voltage until the element resets. Measure the reset voltage level to check the **81 Hysteresis** setting.

F (Hertz)	U/O	DTL (sec)	Hyst.	D.O. (calc.)	P.U. Freq Hertz	D.O. Freq. Hertz	Operate Time +/- 0.5Hz	UV Guard	NOTES

If the element is set as **81-nU/V Guarded**, this setting can be tested by applying the test voltage at a level below the **81 U/V Guard Setting** at a frequency in the operate range. Increase the voltage until the relay operates.

UVG	UVG Setting (Volts)	Freq element Used for test	Blocked Volts (D.O.)	Unblocked Volts (P.U.)	NOTES
U/O Freq					

2.14.1.1 Element Blocking

The U/O Frequency elements can be blocked by Binary Input Inhibit. This functionality should be checked.

Element	BI Inhibits
81-1	
81-2	
81-3	
81-4	

Check correct indication, trip output, alarm contacts, waveform record.

When testing is complete reinstate any of the disabled functions.

Section 3: Supervision Functions

3.1 CB Fail (50BF)

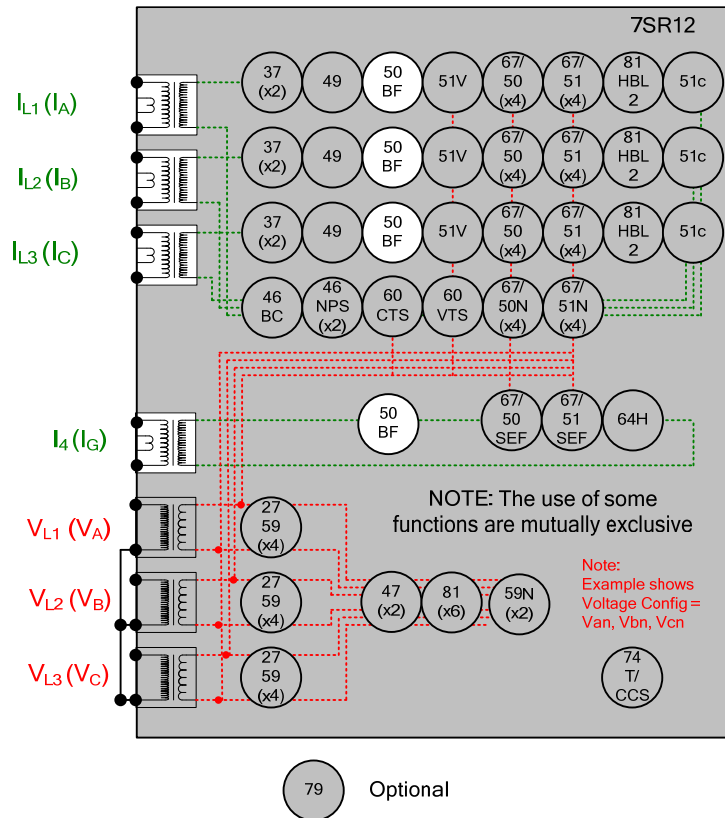

Figure 2-18 CB Fail

Voltage Inputs:	n/a
Current Inputs:	I_{L1} (I_A), I_{L2} (I_B), I_{L3} (I_C), I_{L4}
Disable:	
Map Pickup LED:	50BF-n - Self Reset

The circuit breaker fail protection time delays are initiated either from:

- A binary output mapped as **Trip Contact** in the OUTPUT CONFIG>BINARY OUTPUT CONFIG menu,
- or
- A binary input mapped as **50BF Ext Trip** in the INPUT CONFIG>INPUT MATRIX menu.
- Or
- A binary input mapped as **50BF Mech Trip** in the INPUT CONFIG>INPUT MATRIX menu.

Apply a trip condition by injection of current to cause operation of a suitable protection element. Allow current to continue after the trip at a level of 110% of the *50BF Setting* current level on any phase. Measure the time for operation of *50BF-1 Delay* and *50BF-2 Delay*. Repeat the sequence with the 50BF CB Faulty input energised and ensure the 50BF-1 and 50BF-2 outputs operate without delay, by-passing the timer delay settings.

Repeat the sequence with current at 90% of the *50BF Setting* current level after the element trip and check for no CB Fail operation.

Repeat the sequence by injecting the current to I_4 and using the *50BF-I4 Setting*.

50BF Setting (xIn)	Test Current	50BF-1 Delay.....	50BF-2 Delay.....
	(110%).....		
	(90%).....	No Operation <input type="checkbox"/>	No Operation <input type="checkbox"/>
	50BF CB Faulty	Operation No Delay <input type="checkbox"/>	Operation No Delay <input type="checkbox"/>
50BF-I4 Setting (xIn)	Test Current	50BF-1 Delay.....	50BF-2 Delay.....
	(110%).....		
	(90%).....	No Operation <input type="checkbox"/>	No Operation <input type="checkbox"/>
	50BF CB Faulty	Operation No Delay <input type="checkbox"/>	Operation No Delay <input type="checkbox"/>

If the circuit breaker can also receive a trip signal from a protection function where there is no increase in current, this trip input should be mapped to **50BF Mech Trip** in the INPUT CONFIG>INPUT MATRIX menu.

Initiate this binary input and simulate the circuit breaker remaining closed by ensuring the CB Closed binary Input is energised and ensure operation of the 50BF-1 and 50BF-2 outputs after their programmed delays.

50BF Mech Trip		50BF-1 Delay.....	50BF-2 Delay.....
	CB Closed		
	CB Open	No Operation <input type="checkbox"/>	No Operation <input type="checkbox"/>

3.1.1 Element Blocking

The CB Fail function can be blocked by Binary Input Inhibit. This functionality should be checked.

Element	BI Inhibits
50BF	

3.2 Voltage Transformer Supervision (60VTS)

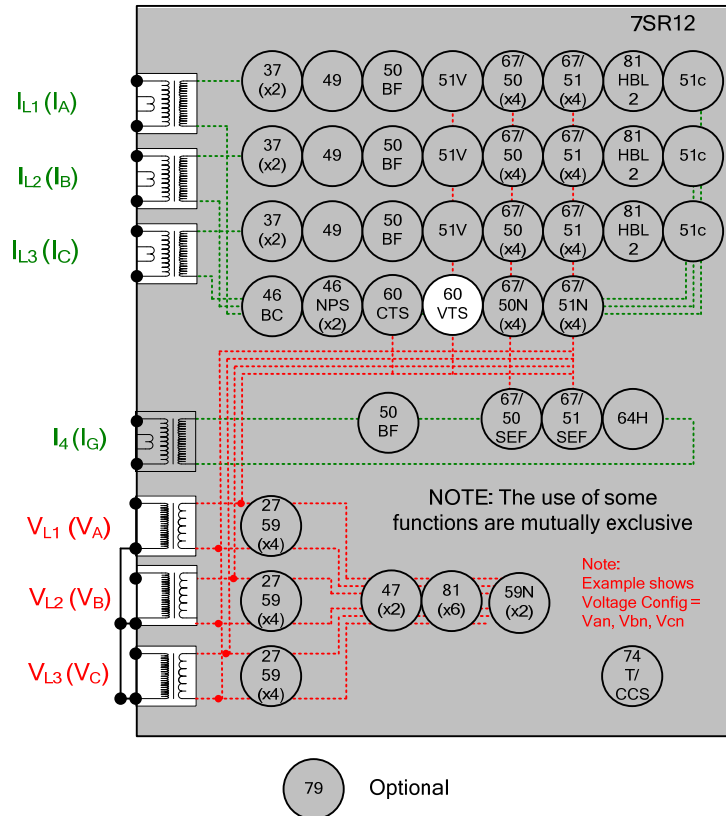

Figure 2-19 Voltage Transformer Supervision

- Voltage Inputs: $V_{L1} (V_A), V_{L2} (V_B), V_{L3} (V_C)$
- Current Inputs: $I_{L1} (I_A), I_{L2} (I_B), I_{L3} (I_C),$
- Disable: 27, 47, 59N
- Map Pickup LED: 60VTS - Self Reset

3.2.1 1 or 2 Phase VT fail

Apply 3P balanced nominal current and voltage. Reduce 1 phase voltage until VTS operates, record voltage reduction level.

60VTS V Setting	Setting x 3	Measured Voltage Reduction

Increase the voltage until VTS resets. Increase current on 1 phase by 110% of 3x the 60VTS / setting. Reduce voltage as above and check for no operation. Return voltage to nominal. Increase current on 1 phase by 90% of 3x the 60VTS / setting. Reduce voltage as above and check for VTS operation

60VTS I Setting	Setting x 3	110% of Setting x 3	90% of Setting x 3
		No VTS <input type="checkbox"/>	VTS operation <input type="checkbox"/>

3.2.2 3 Phase VT fail

Apply 3P balanced nominal voltage and 3P balanced current at a level between the *60VTS Ipps Load* setting and the *60VTS Ipps Fault* setting. Reduce the balanced Voltage on all 3 phases until the VTS operates at the *60VTS Vpps* setting. Return the voltage to nominal and ensure that VTS resets.

Reduce the 3P balanced current to a level below the *60VTS Ipps Load* setting. Reduce the 3P balanced voltage to a level below the operate level above. Gradually increase the 3P balanced current until the VTS operates.

Check that the thermal rating of the relay current inputs is not exceeded during the following test. Increase the 3P balanced current to a level above the *60VTS Ipps Fault* setting. Reduce the 3P balanced voltage to a level below the operate level above. Gradually reduce the 3P balanced current until the VTS operates.

	Setting	Measured
60VTS Vpps		
60VTS Ipps Load		
60VTS Ipps Fault		

If the VTS can be started from a status input fed from an external source, this functionality should be tested.

Ext_Trig 60VTS Operation Not Applicable

3.2.2.1 Element Blocking

The VT Supervision can be blocked by Binary Input Inhibit. This functionality should be checked.

Element	BI Inhibits
60VTS	

3.3 Current Transformer Supervision (60CTS)

3.3.1 7SR11

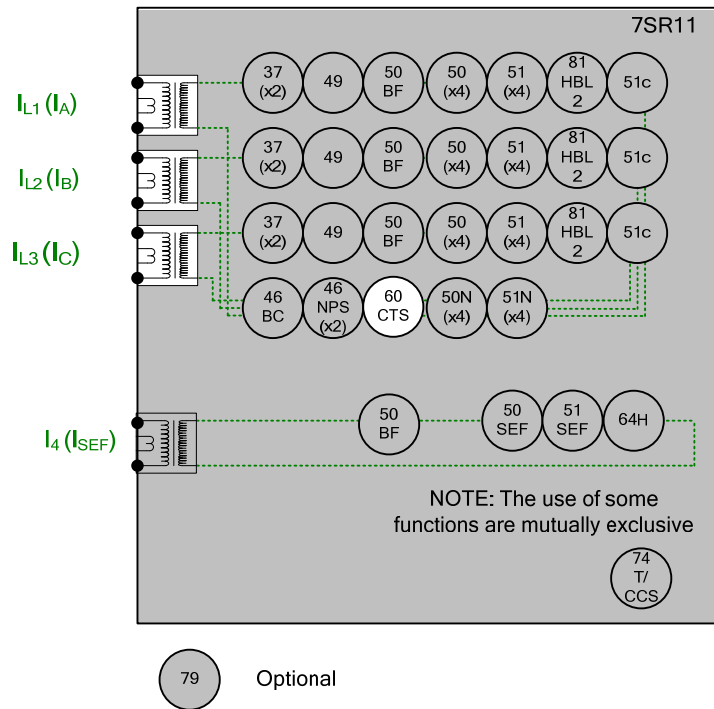

Figure 2-20 Current Transformer Supervision 7SR11

Current Inputs: $I_{L1} (I_A)$, $I_{L2} (I_B)$, $I_{L3} (I_C)$
 Disable: 51N, 46IT, 46DT, 46BC
 Map Pickup LED: 60CTS - Self Reset

Apply 3Phase balanced current to the relay, reduce the current in any one or two phases to a level below 60CTS / setting. Measure the delay to operation.

Gradually reduce the 3Phase current until the element resets.

Setting	Measured
60CTS Delay	
60CTS Inps	
60CTS Vnps	

3.3.2 7SR12

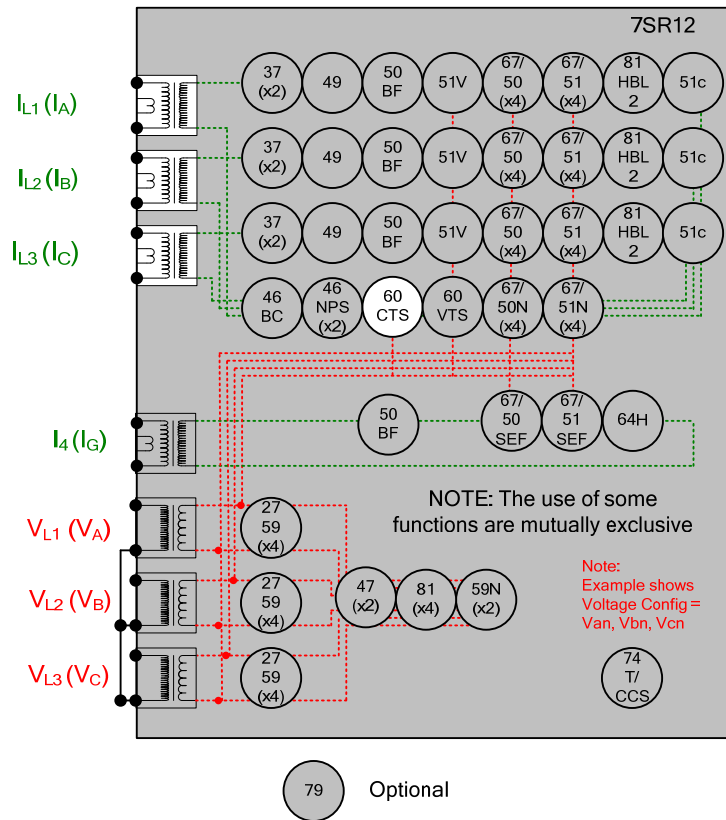

Figure 2-21 Current Transformer Supervision 7SR12

- Voltage Inputs: $V_{L1} (V_A), V_{L2} (V_B), V_{L3} (V_C)$
- Current Inputs: $I_{L1} (I_A), I_{L2} (I_B), I_{L3} (I_C)$
- Disable: 51N, 46IT, 46DT, 46BC
- Map Pickup LED: 60CTS - Self Reset

The presence of NPS current without NPS voltage is used to indicate a current transformer failure.

Apply normal 3P balanced current with a crossover of any two phases at a level above 60CTS Inps setting. Measure the delay to operation.

Apply 3P balanced voltage with a similar phase crossover to the current. Increase the applied 3P voltage until the CTS element resets.

Reduce the 3P voltage to cause CTS operation again. Gradually reduce the 3P current until the element resets.

Setting	Measured
60CTS Delay	
60CTS Inps	
60CTS Vnps	

3.3.2.1 Element Blocking

The CT Supervision function can be blocked by Binary Input Inhibit. This functionality should be checked.

Element	BI Inhibits
60CTS	

3.4 Broken Conductor (46BC)

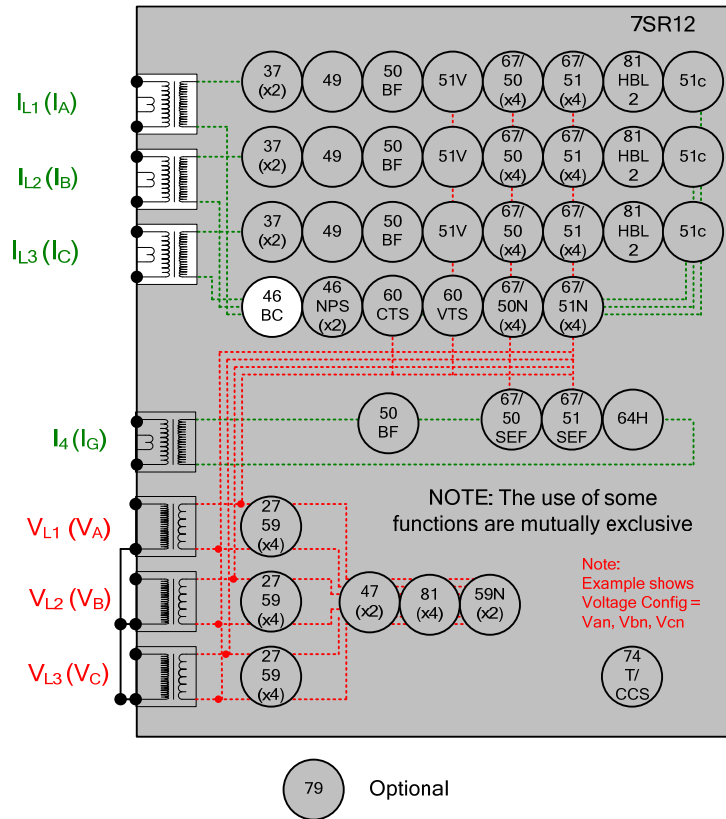

Figure 2-22 Broken Conductor

- Voltage Inputs: n/a
- Current Inputs: I_{L1} (I_A), I_{L2} (I_B), I_{L3} (I_C)
- Disable: 51N, 46IT, 46DT
- Map Pickup LED: 46BC - Self Reset

Broken Conductor uses the ratio of NPS current to PPS current to detect an open circuit conductor. These quantities can be produced directly from many advanced test sets but with limited equipment the following approach can be applied.

Apply 3P balanced current with normal phase rotation direction. This current will consist of PPS alone, no NPS or ZPS.

Increase 1 phase current magnitude in isolation to produce NPS. The single phase unbalance current will contain equal quantities of ZPS, NPS and PPS. The NPS component will be 1/3 of the unbalance current and the total PPS component will be value of the original balanced 3P current plus 1/3 of the additional unbalance current. i.e. as the single phase unbalance current increases, the ratio of NPS to PPS will also increase. The levels of each sequence component current can be monitored in the **Current Meters** in **Instruments Mode**.

Inject 1A of balanced current. Gradually increase imbalance current, operating level should be as follows:

46BC Setting	1P unbalance current (% of 3P current)
20%	75%
25%	100%
30%	129%
35%	161%
40%	200%

46BC Setting	3P balanced current (A)	1P unbalance current (A)	Measured Unbalance current

Apply 1A 1P unbalance current without 3P balanced current. Measure 46BC operating time.

46BC Delay setting	Measured

3.4.1.1 Element Blocking

The Broken Conductor element can be blocked by Binary Input Inhibit. This functionality should be checked.

Element	BI Inhibits
46BC	

3.5 Trip/Close Circuit Supervision (74T/CCS)

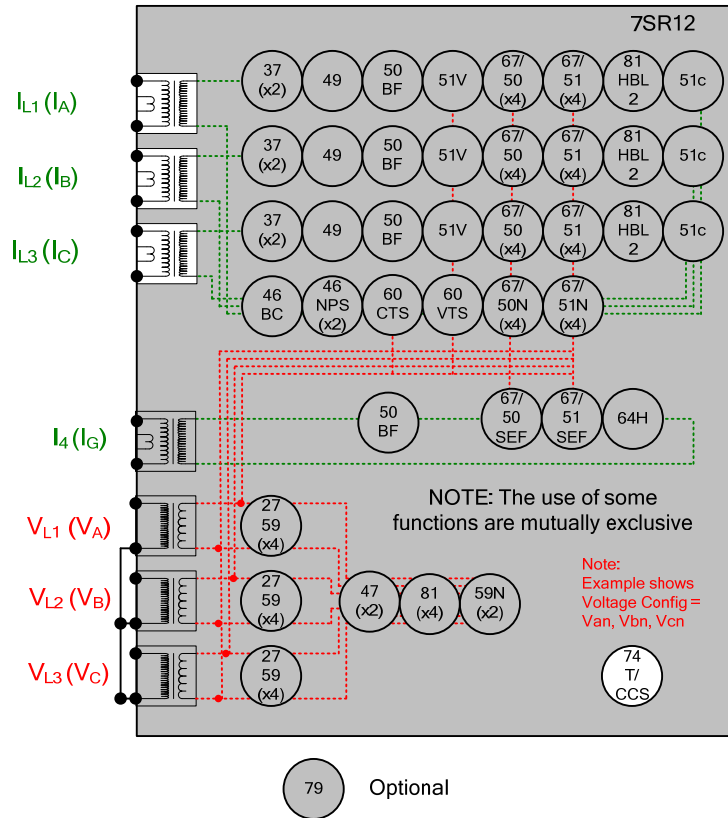

Figure 2-23 Trip Circuit Supervision

Voltage Inputs:	n/a
Current Inputs:	n/a
Disable:	
Map Pickup LED:	74TCS-n - Self Reset

The T/CCS-n Delay can be initiated by applying an inversion to the relevant status input and measured by monitoring of the alarm output.

TCS-n Delay setting	Measured
CCS-n Delay setting	Measured

3.6 Magnetising Inrush Detector (81HBL)

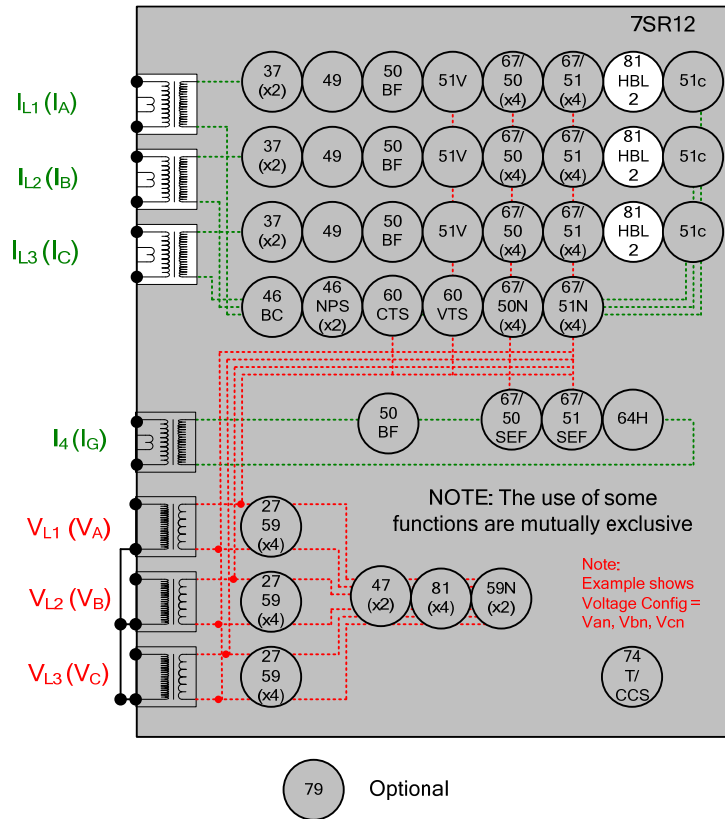

Figure 2-24 Magnetising Inrush Detector

Voltage Inputs:	n/a
Current Inputs:	I_{L1} (I_A), I_{L2} (I_B), I_{L3} (I_C),
Disable:	
Map Pickup LED:	

Logical operation of the harmonic blocking can be tested by current injection at 100Hz to cause operation of the blocking signals.

Section 4: Control & Logic Functions

4.1 Autoreclose (79)

Autoreclose sequences can be specified differently for Phase, Earth, Externally Initiated and SEF faults. Sequences should be simulated for each applicable different fault type with the actual relay settings required for service installed in the relay.

The relay requires that the correct indications are received at the CB auxiliary contact inputs and that the injected current and voltage used to generate protection operations are timed to the autoreclose sequence to provide a realistic simulation of the actual system conditions.

The Instruments Menu contains Autoreclose Meters for the Autoreclose State and the Shot No. which are useful during sequence testing.

The time stamped Events listing can be downloaded from the relay to a pc to allow diagnosis of the sequence including measurements of sequence Dead Times and other timing without the use of external measuring equipment or complex connections.

4.2 Quick Logic

If this functionality is used, the logic equations may interfere with testing of other protection functions in the relay. The function of the Quick Logic equations should be tested conjunctively with connected plant or by simulation to assess suitability and check for correct operation on an individual basis with tests specifically devised to suit the particular application.

Section 5: Testing and Maintenance

The relays are maintenance free, with no user serviceable parts.

5.1 Periodic Tests

During the life of the relay, it should be checked for operation during the normal maintenance period for the site on which the product is installed. It is recommended the following tests are carried out:-

- Visual inspection of the metering display
1. Operation of output contacts
 2. Secondary injection of each element

5.2 Maintenance

Relay failure will be indicated by the 'Protection Healthy' LED being off or flashing. A message may also be displayed on the LCD. In the event of failure Siemens Protection Devices Ltd. (or one of its agents) should be contacted – see defect report sheet in section 5.3.

The relay should be returned as a complete unit. No attempt should be made to disassemble the unit to isolate and return only the damaged sub-assembly. It may however be convenient to fit the withdrawable relay to the outer case from a spare relay, to avoid the disturbance of relay panel wiring, for return to Siemens Protection Devices Ltd. The withdrawn relay should never be transported without the protection of the outer case.

5.3 Troubleshooting

Observation	Action
Relay does not power up.	Check that the correct auxiliary AC or DC voltage is applied and that the polarity is correct.
Relay won't accept the password.	<p>The Password being entered is wrong. Enter correct password. If correct password has been forgotten, note down the Numeric Code which is displayed at the Change Password screen e.g.</p> <div style="border: 1px solid black; padding: 5px; width: fit-content; margin: 10px auto;"> <p style="text-align: center;">Change password = 1234567</p> </div> <p>To retrieve the password, communicate this code to a Siemens Protection Devices Ltd. representative.</p>
Protection Healthy LED flashes	General failure. Contact a Siemens Protection Devices Ltd. representative.
LCD screen flashes continuously.	<p>The LCD has many possible error messages which when displayed will flash continuously. These indicate various processor card faults.</p> <p>General failure. Contact a Siemens Protection Devices Ltd. representative.</p>
Backlight is on but no text can be seen.	Adjust the contrast.
Scrolling text messages are unreadable.	Adjust the contrast.
Relay displays one instrument after another with no user intervention.	<p>This is normal operation, default instruments are enabled. Remove all instruments from the default list and only add those that are required.</p> <p>(See Section 2: Settings and Instruments).</p>
Cannot communicate with the relay.	<p>Check that all of the communications settings match those used by Reydisp Evolution.</p> <p>Check that all cables, modems and fibre-optic cables work correctly.</p> <p>Ensure that IEC 60870-5-103 is specified for the connected port (COM1 or COM2).</p>
Relays will not communicate in a ring network.	<p>Check that all relays are powered up.</p> <p>Check that all relays have unique addresses.</p>

Observation	Action
Status inputs do not work.	Check that the correct DC voltage is applied and that the polarity is correct. Check that the status input settings such as the pick-up and drop-off timers and the status inversion function are correctly set.
Relay instrument displays show small currents or voltages even though the system is dead.	This is normal. The relay is displaying calculation noise. This will not affect any accuracy claims for the relay.

Table 2-1 Troubleshooting Guide

If the above checklist does not help in correcting the problem please contact the local Siemens office or contact PTD 24hr Customer Support, Tel: +49 180 524 7000, Fax: +49 180 524 2471, e-mail: support.energy@siemens.com.